

**VILLAGE OF  
PHILO, ILLINOIS**

**SUBDIVISION ORDINANCE**

**VILLAGE OF PHILO SUBDIVISION ORDINANCE OF 1996  
WITH AMENDMENTS THROUGH DECEMBER 7, 2005**

**1996 SUBDIVISION ORDINANCE NO. 454  
ADOPTED BY THE  
PRESIDENT AND BOARD OF TRUSTEES  
OF THE VILLAGE OF PHILO,  
CHAMPAIGN COUNTY, ILLINOIS  
ON THE 15<sup>TH</sup> DAY OF MAY 1996**

**AMENDING ORDINANCE NO. 533  
ADOPTED BY THE  
PRESIDENT AND BOARD OF TRUSTEES  
OF THE VILLAGE OF PHILO,  
CHAMPAIGN COUNTY, ILLINOIS  
ON THE 7<sup>th</sup> DAY OF DECEMBER, 2005**

**VILLAGE OF PHILO  
SUBDIVISION ORDINANCE OF 1996  
WITH AMENDMENTS THROUGH DECEMBER 7, 2005**

AN ORDINANCE adopting subdivision procedures and standards for subdivisions, within the corporate limits of the Village of Philo, Illinois, and within one and one-half miles thereof.

BE IT ORDAINED by the President and Board of Trustees of the Village of Philo, Illinois, as follows:

ITEM I

That this Ordinance shall be known and referred to as the Philo Subdivision Ordinance of 1996. If any provisions of this ordinance shall hereafter be held invalid, said decision shall not affect the validity of the remaining provisions of this Ordinance. Any former ordinance inconsistent with the provisions of this Ordinance is hereby repealed to the extent of such inconsistency.

ITEM II

That the following procedures and standards shall govern the subdivisions of land within the corporate limits of the Village of Philo, Illinois, and within one and one-half miles thereof, to-wit:

SECTION 1.1 PURPOSE OF REGULATIONS

These regulations are designed to provide standards and rules related to the making, reviewing, filing and recording of subdivision plans and plats, and to provide for preliminary and final approval or rejection of such plans or plats, or portions thereof, by the Village of Philo, Champaign County, Illinois, and as set forth in this ordinance.

Subdivision of land shall mean the division of land as defined in the Illinois Revised Statutes, and as defined herein.

SECTION 1.2 OBJECTIVE OF REGULATIONS

Pursuant to the authority conferred by the Statutes of the State of Illinois, the objectives of these regulations are to provide for the orderly growth and harmonious development of the Village of Philo: to secure adequate traffic circulation by means of coordinated street systems with relation to major thoroughfares and streets adjoining subdivisions, public walkways, public facilities and other land uses, to achieve individual lots of reasonable utility and livability, to facilitate adequate provisions for transportation, water supply, drainage, sanitary sewerage, and health requirements, to encourage the installation of street lights and street trees, to encourage adequate provisions for recreational areas, open space, school sites, and other public ways and facilities, to encourage the installation of underground utilities; to provide for the further subdivision of tracts into smaller or larger parcels of land, and to provide administrative and review procedures for the attainment of these objectives.

### SECTION 1.3 NOTICE OF PREVIOUS ADOPTIONS OF ZONING ORDINANCE AND DISTRICT MAP

All proposed subdivisions shall comply with the "Zoning Ordinance of the Village of Philo, Illinois," with respect to zoning districts, and uses therein, and all amendments thereto.

### SECTION 1.4 SUBDIVISION CONTROL

That for the purpose of the present and future development of the Village of Philo and for the promotion of Public Health and Safety, morals, comfort and welfare of persons living within the territory governed, the provisions and regulations hereinafter contained shall govern the subdivision and plotting of land lying within the corporate limits of the Village of Philo as now or hereafter existing, or within the area of jurisdiction of the Village of Philo as now and hereafter established under the provisions of the statutes of the State of Illinois, presently one and one-half miles beyond the Village corporate limits.

### SECTION 1.5 APPROVAL

After the passage of this Ordinance, no Plat of any Subdivision shall be valid or entitled to recording without conforming to the regulations herein set forth and without having first been approved according to the procedure herein provided. Prior to such recording, no lot or parcel of land within any such Subdivision shall be offered for sale nor shall any sale, contract for sale or option be made with respect thereto, nor shall any specific improvements, in and with respect to such Subdivision, be made.

### SECTION 1.6 DEFINITIONS

When used in this Ordinance, the following terms shall have the meaning indicated:

Alley - is a public way which affords a secondary means of access to abutting property.

Area General Plan - is a general plan prepared by the subdivider, or subdividers, or the progressive development of a large landholding, or several properties proposed to be subdivided by sections, meeting the requirements of these regulations.

Block - is a property abutting on one side of a street, and lying between the two nearest intersecting or intercepting streets, or between the nearest intersecting or intercepting street and railroad right-of-way, waterway or other definite barrier.

Block Face - is property having frontage on one side of a street and lying between the two nearest intersecting streets, or nearest intersecting or intercepting street and railroad right-of-way, waterway or other barrier.

Building Setback Line - is a line within a lot or other parcel of land so designated on the plat of the proposed subdivision between the adjacent boundary of the

street or lot line upon which the lot abuts and which the erection of an enclosed structure or portion thereof is prohibited.

Boulevard - is a street, other than a freeway or an expressway, developed with two-lane, one-way pavements separated by a landscaped island, median or barrier.

Butt Lots - are lots the rear lot lines of which abut the side lot lines of other lots platted in the same block and not separated therefrom by an alley or other open space.

Comprehensive Plan - is an official advisory plan of jurisdiction formally adopted by a municipality or the County, and part of which may be implemented by ordinance duly enacted by the Corporate Authorities as prescribed by the Illinois Municipal Code. Said plan shall be placed on file with the Village Clerk and with the Champaign County Clerk.

Crosswalk - is a public or private right-of-way across a block to be used by pedestrians and/or for underground utilities.

Cul-de-sac - is a local street having one open end being terminated at the other by a vehicular turn-around.

Culvert - is a transverse drain that channels under a street, alley or driveway.

Dedication - is the deliberate appropriation of land by its owner for any general public uses, reserving to himself no other right than such as are compatible with the full exercise and enjoyment of the public uses to which the property has been devoted.

Drainage Basin - is an area of land which, because of the nature of the topography, collects naturally the surface drainage of the surrounding land.

Easement - is the quantity of land set aside or over which a liberty, privilege, or advantage in land, without profit existing distinct from the ownership of the land, is granted to the public or some particular person or part of the public.

Final Plat - is a drawing of a subdivision which has been accurately surveyed - and such survey marked on the ground so that streets, alleys, blocks, lots or other divisions thereof can be identified.

Flood - is an overflow of water on lands adjacent to a river, stream, lake, not normally covered by water.

Flood Plain - is the land adjacent to a body of water which has been or may be hereafter covered by floodwater.

Local Street - means minor streets providing direct access to abutting property, which may be devoted to residential, commercial, or other uses. Streets in this classification are not considered part of the major thoroughfare system.

Lot - is a portion of a subdivision, or other parcel of land intended as a unit for transfer of ownership or for development.

Lot Area - is the horizontal protection (in square feet) of a parcel of land or a body of water, or combination of both, exclusive of any portion of the right-of way of any public or private streets; measurements are to be made by standard surveying practice methods.

Lot Corner - is a parcel of land at the junction of and fronting or a butting on two or more intersecting streets.

Lot Depth - is the average distance between the front and rear line of a lot measured in the general direction of its side lot lines.

Lot Interior - is a lot other than a corner lot.

Lot Width - for regular-shaped lots, the average distance between the side lines of a lot measured at right angles to the depth of the lot. For pie-shaped lots the lot width shall be measured at the building setback line.

Marginal Access Street (Frontage Road) - is a local street or highway paralleling, adjacent to and having limited access to a freeway, expressway, collector highway, area service highway, or land access highway which provides direct access to abutting property and protection from through traffic.

Monument - is a physical structure which marks the location of a corner or other survey point as required by provisions contained herein.

Official Plan - is the complete plan, or any of its parts, for the development of the Village prepared by the Village of Philo and adopted in accordance with the Illinois Revised Statutes, as are now or may hereafter be in effect.

Owner - is any person(s), firm, association, partnership, or corporation having any legal, equitable, or beneficial interest in the land sought to be subdivided.

Plan Commission - The legally appointed members and officers of the Philo Plan Commission as provided by the Village Board.

Plat Officer - the Village Clerk.

Preliminary Plat - is a preliminary drawing and supporting data, indicating the proposed layout of the subdivision in sufficient detail to provide adequate basis for review by the Village of Philo, meeting the requirements of these regulations.

Public Improvements - are street pavements, public walkways, monuments, water mains, sanitary and storm sewers, street signs, culverts and appurtenances to the foregoing items and for use by the public.

Public Walkway - is a right-of-way dedicated for the purpose of pedestrian access and located so as to connect two or more streets, or a street and a public land parcel, or any two public parcels of land.

Reproducible Copy - is a print or copy of a plat or drawing on transparent film or mylar of adequate weight to withstand handling.

Setback Line - is the line within a property defining the required minimum distance between any enclosed structure and the adjacent or proposed right-of-way line of a street.

Sidewalk - is a pedestrian walkway within the public right-of-way or easement.

Sketch Plan - is a preliminary drawing indicating the proposed general development of the area to be subdivided.

Street (Highway) - is a right-of-way, whether designated as a street, highway, road, lane, court, thoroughfare, parkway, freeway, expressway, boulevard, or avenue, other than an alley or place, usually affording the principal means of access to abutting property.

Street Arterial - is a public thoroughfare with a high degree of traffic continuity established in the official plan of the Village.

Street Collector - is a street which carries traffic from minor streets to the arterial street system, including the principal entrance streets of residence development and the primary circulating streets within such a development.

Street Line - is the dividing line between the street or highway right-of-way and the lot.

Subdivision - is a division of a lot, tract, or parcel of land into two or more lots, or other divisions of land, for the purpose whether immediate or future, of (1) transfer of ownership, (2) building development, or (3) redevelopment, including all changes in street lines, provided that divisions of land in parcels of five acres or more not involving any new street or easement of access, and other enumerated situations shall be exempted as set forth in Chapter 109 of the Illinois Revised Statutes.

Subdivision Design Standard - is the officially adopted guides, principles, specifications and standards for the preparation of subdivision plans and plats indicating, among other things, the maximum and minimum dimensions of the various elements set forth in the area general plan, preliminary plat or final plat.

Tentative Approval - is an approval with or without recommended alterations given to a preliminary plat by the Commission and provides the necessary authority to proceed with the preparation and presentation of the final plat.

Thoroughfare - is any part of the Official Plan of the Village of Philo, now or hereafter adopted which sets forth the location, alignment, dimensions, identification and classification of existing and proposed public streets, highways and other thoroughfares.

Variance - is a modification of the strict terms of the relevant regulations where such modification will not be contrary to the public interest and where, owing to conditions peculiar to the property and not the result of the action of the

applicant, a literal enforcement of the regulations would result in unnecessary and undue hardship.

Vicinity Map - is a drawing located on the preliminary plat which sets forth by dimensions or other means, the relationship of the proposed subdivision or use to the nearby developments, landmarks, community facilities or services.

Village - means the Village of Philo, Illinois.

Village Board - the Board of Trustees of the Village of Philo, Champaign County, Illinois.

## SECTION 1.7 SUITABILITY OF LAND FOR SUBDIVISIONS

Lands subject to flooding and land deemed to be topographically unsuitable should not be subdivided for residential purposes, nor for such other uses as may increase danger to health, life or property, or aggravate erosion or flood hazards.

The Plan Commission shall not approve the subdivision of land if upon adequate investigation conducted by the Plan Commission it has been determined by the Plan Commission that in the best interest of the public, the site is not suitable for the subdivision and development of the kind proposed.

## SECTION 2.1 PROCEDURES

### A. Zoning

1. If the proposed subdivision lies within the Corporate Limits of the Village of Philo, the developer must first satisfy the zoning requirements of the Zoning Ordinance of the Village of Philo, Illinois, as adopted, and as amended.
2. If the proposed subdivision lies outside the Corporate Limits of the Village of Philo, but within a one and one-half mile area of said Corporate Limits, then the developer must first satisfy the zoning requirements in "Champaign County Zoning Ordinance," as adopted September 11, 1973 as amended.

## SECTION 2.2 SUBMISSION PHASES

Subdivision planning, review approval and acceptance shall proceed through the following sequential phases:

Informal Discussion Phase, Preapplication Conference

Preliminary Plat Review and Approval Phase

Final Plat Review and Approval Phase

Final Engineering Plans and Approval Phase

Recording Phase

Construction

Acceptance of Public Improvements by the Village of Philo

### SECTION 2.3 DUTIES AND RESPONSIBILITIES

The purposes and objectives regarding land subdivision can best be understood by considering the various duties and responsibilities associated with land subdividing. The specific duties and responsibilities of the individual or groups listed below are clearly identified in these regulations.

A. Subdivider

The Subdivider is responsible for initiating discussions with the Village of Philo before thoroughly preparing any subdivision plans or plats in order to become familiar with these regulations and the public policies and objectives applicable to the territory in which the proposed subdivision lies.

B. Engineer and Surveyor

The Engineer and Surveyor acting on behalf of the subdivider are responsible for preparing the necessary subdivision plans, surveys and plats and the engineering drawings and specifications as required by these regulations.

C. Reviewing Authority

The reviewing authorities are the Plan Commission and Board of Trustees of the Village of Philo which are responsible for reviewing the subdivision plan or plat, or portions thereof, and, respectively, recommending approval and approving those that fully meet the provisions and requirements of these regulations.

D. Plat Officer

The Village Clerk shall serve as the Plat Officer and shall receive plans, plats, and other documents as herein provided and furnish them to the various parties involved as provided in this Ordinance.

### SECTION 2.4 INFORMAL DISCUSSION PHASE

Purpose - The purpose of the informal discussion phase, insofar as possible, is to guide and assist the subdivider in his future decisions with a view to avoiding later difficulties and delays. This is the basic policy state, during which the subdivider meets informally with the Philo Plan Commission. In the course of the discussion the subdivider should make known his tentative plans for subdividing and development, may exhibit sketch plans and shall be apprised by the Philo



Plan Commission concerning specific public policies and objectives which the Commission may have for the area in question. Discussion at this phase shall involve the entire area of ownership and anticipated development.

The subdivider shall be prepared to discuss compliance with the regulations of other units of government or agencies or offices thereof which may have jurisdiction, review authority or a recognized policy interest over the project, such as Illinois Department of Transportation, Illinois Environmental Protection Agency, Department of Public Health, Drainage District, etc., and any other entity identified by the Village Engineer or involved as a matter of law.

## SECTION 2.5 PROCEDURES FOR REVIEW

Submission - A preapplication conference may be requested by all subdividers prior to initial plat application. Subdividers may contact the Chairman of the Plan Commission to arrange a preapplication conference. Subdividers may submit an Area General Plan with material sufficient to identify the tract and establish the relationship of the proposed development with surrounding area.

Processing - Upon a request for a preapplication conference, the Chairman of the Plan Commission shall schedule the preapplication conference at the next regular meeting of the Plan Commission. All materials will be considered as submitted for informal discussion. Discussions will involve the proposals in compliance with these regulations, determination of the scope of the proposed subdivision, an outline of the procedures for the recording of plats and general information exchange. No approvals will result from this conference; however, the Plan Commission may make recommendations on the scope of the initial plat application by the subdivider, continuity of the proposed street pattern with existing or proposed streets adjacent to the proposed subdivision, and other factors based on peculiarities of the area in which the subdivision is prepared.

Review - Review of any material submitted by the subdivider during the informal discussion phase shall be made by the Plan Commission. Any sketch plan submitted, shall be studied with regard to the best principles of land subdividing and development, (i.e.), to lot sizes and proportions, to existing and planned land uses, to topography and drainage, to provisions for recreation area, public open space, schools, parks, and other public facilities, to design and location of streets, and to conformity with the continuity of existing street system, walkways and related matters.

Inspection - The Plan Commission may make an inspection of the site to determine its relationship to and effect upon major thoroughfares, utilities, and adjacent land uses (existing and planned) and ascertain the existence of any unusual problems, and shall determine:

- A. The conformity of the proposed development to existing zoning regulations, official road maps, and municipal development plans and policies;
- B. The effect of the proposed development upon schools, public open spaces, and other nearby community facilities;

- C. The need for preparation and review of an Area General Plan prior to consideration of the preliminary plat.

### SECTION 3.1 AREA GENERAL PLAN SUBMISSION

An Area General Plan may be prepared and submitted by the subdivider, for approval by the Plan Commission, prior to the submission of the initial preliminary plat. The Plan Commission shall determine that either of the following conditions exists to warrant a requirement of preparation and submission of an Area General Plan:

- A. The parcel initially proposed for platting constitutes a portion of a larger tract of land owned, or under option to purchase by the subdivider;
- B. The parcel initially proposed for platting constitutes a portion of a larger land area, the development of which will be complicated by unusual problems of drainage, street layout, utility services, land usage, or land ownership pattern.

The Area General Plan shall show property boundaries, existing easements, land characteristics including wetlands, drainage, flood-prone areas as identified on Flood Prone Area Maps of the Flood Insurance Agency, wooded areas and major topographic features, development characteristics, streets, existing buildings, sewer lines, water lines and pipelines. Also to be shown in the Area General Plan are the proposed layout of streets, blocks and lots; proposed location of commercial areas, and parks or other public areas. The Area General Plan shall be prepared to a proper scale of one inch equals one hundred feet (1 in. = 100 ft.) or larger, and to proper accuracy.

The Plan Commission shall review the Area General Plan at a regular meeting for compliance with these regulations and its consistency with the Philo Official Plan and applicable municipal development plans, or parts thereof. Commission action shall take the form of approval or denial within thirty (30) days following the complete submittal of the Area General Plan and such action shall be indicated on the Area General Plan.

The Area General Plan may serve as the subdivider's official preliminary plat, provided that the Area General Plan submitted as the official preliminary plat by the subdivider, conforms to the requirements as set forth in these regulations. In the event the Plan Commission approves the Area General Plan as the official preliminary plat, the subdivider may submit the final plat for review and approval as provided in these regulations.

A portion of the Area General Plan may serve as the subdivider's official preliminary plat, provided that this portion is clearly designated and provided that this portion of the Area General Plan submitted as the official preliminary plat by the subdivider conforms to the requirements as set forth in these regulations for preliminary plats.

## SECTION 4.1 PRELIMINARY PLAT SUBMISSION

Purpose - The purpose of the preliminary plat phase, insofar as possible, is to assist the subdivider and the reviewing authorities in determining whether the proposed subdivision conforms to the standards and requirements of these regulations and the tentative approved Area General Plan, and the pertinent standards and regulations of affected municipal departments. The preliminary plat is the document which shall be used for review by the Plan Commission.

- A. The developer shall submit to the Plat Officer seven (7) copies of the preliminary plat fourteen (14) calendar days prior to the next regular meeting of the Plan Commission. If the developer does not satisfy these requirements, the preliminary plat shall not be considered.
- B. The preliminary plat, and/or accompanying documents shall contain the information herein specified and comply with the following requirements set forth in Section 4.2. hereof.
- C. The developer shall also submit to the plat officer seven (7) copies of any request for waivers from the requirements of the Philo Subdivision Ordinance.
- D. The developer shall submit with the preliminary plat a filing fee of ten dollars for each lot or two hundred dollars, whichever is greater. The check should be made payable to the Village Clerk of Philo.

### SECTION 4.1.1. WAIVER OF PRELIMINARY PLAT

- A. The subdivider may request that the Plan Commission waive submission of a preliminary plat. The Plan Commission may grant the subdivider's request to waive submission of a preliminary plat under the following conditions:
  - 1. The development is in an agriculture, single family residence or conservation zoned district under the Village of Philo Zoning Ordinance, whichever is applicable.
  - 2. The development is to be used only for single family residences.
  - 3. The development involves four or fewer lots.
  - 4. The development involves no construction or extension of public improvements.
- B. If the preliminary plat is waived, the following requirements apply:
  - 1. With the final plat, the developer shall submit a plat showing location of all building improvements on the tract of land, all public utilities on or adjacent to the tract of land, utility services connections, utility easements and the general drainage of the tract of land.

2. The developer shall submit the final plat to all other units of government which may have jurisdiction or review authority over the project, as specified in the preliminary plat section of this ordinance (Section 2.4).
3. The filing fee shall be the same as specified in the preliminary plat section of this ordinance (Sections 4.1 and 4.3).

SECTION 4.2 GENERAL REQUIREMENTS

- A. Proposed name of the subdivision with the word "Preliminary" on the proposed plat.
- B. Location of the subdivision by section, township and range or by other legal description.
- C. Names and addresses of the Owner of the subdivision, including the known beneficial owners of any interest of five percent or more.
- D. Date of preparation, northpoint, and;
- E. The name and address of the land surveyor and engineer responsible for the subdivision.
- F. The name of the person or persons to which all correspondence shall be mailed.
- G. Boundary line of proposed subdivision indicated by solid heavy line so designated and the total approximate acreage encompassed thereby.
- H. Indicate current zoning classification and zoning classification of adjacent tracts.

SECTION 4.3 CHAMPAIGN COUNTY SOIL AND WATER CONSERVATION DISTRICT

- A. Information concerning the proposed subdivision shall be submitted by the developer to the Soil and Water Conservation District with all required fees, for comments as to:
  1. Suitability of soils for building construction and indicate problems that may arise in the event good engineering practices are not followed.
  2. Suitability of soils for septic tank systems, if applicable to the subdivision.
  3. Best use of soils in the area in question.

4. All fees as required by this section shall be paid by the developer directly to the Champaign County Soil and Water Conservation District.
5. Forms shall be obtained by the developer from the Soil and Water Conservation District office.

The developer shall submit a written opinion from the Soil and Water Conservation District concerning the proposed subdivision to the Chairman of the Plan Commission.

#### SECTION 4.4 EXISTING CONDITIONS

- A. Location, width and names of all existing or prior platted streets or other public ways, subdivision, railroad and utility right-of-ways, parks and other public open spaces, permanent buildings and structures, houses, permanent easements, lakes, rivers, streams, drainage ditches, and section and corporation lines within and adjacent to the tract.
- B. Existing sewers, water mains, culverts or other underground facilities within the tract and to a distance of at least one hundred feet beyond the tract boundaries indicating pipe sizes, flow line elevations, grades, manholes and exact locations. All elevations shall be to U.S.G.S. Mean Sea Level Datum.
- C. Adjacent tracts of unsubdivided lands showing ownership where possible.
- D. Contour at vertical intervals of not more than two feet. High water levels of all water courses, if any shall be indicated. The datum used shall be U.S.G.S. Mean Sea Level.
- E. The acreage and description of the drainage basin or basins within which the proposed subdivision lies.
- F. Existing zoning classification of adjacent areas.

#### SECTION 4.5 PROPOSED CONDITIONS

- A. The location and width of proposed street right-of-ways, crosswalks, easements, and other areas to be reserved for public use.
- B. An identification system for all lots and blocks and street names. Lot lines to show approximate dimensions and setback lines. Approximate lot areas should also be shown.
- C. The current zoning classification and areas should be shown.
- D. Distances to the nearest established street lines.
- E. The plan of any proposed water courses or impoundments including stream relocations, showing normal water levels and direction of flow.

- F. The provisions for water supply, sewage disposal, and storm water disposal indicated by a general drainage plan of sufficient detail to show how the water will be moved over the site, and subsurface drainage including provisions for continual maintenance of natural drainage courses and field drainage tile systems. Known on-site field drainage tile systems serving areas off the site shall be located in designated easements.
- G. If a private septic disposal system is proposed for any lot, the preliminary plat shall be submitted to the Champaign County Public Health District for review and approval. All private disposal systems shall be in accordance with the Champaign County Public Health District rules and regulations.
- H. If connection to a public water system is proposed, the preliminary plat shall be submitted to Aqua Illinois for review and approval. All public water systems shall be in accordance with Aqua Illinois rules and standards.
- I. The developer shall submit approval from other units of Government that have approval or review authority over the development such as, Drainage District, Illinois Department of Conservation, Illinois Historic Preservation Agency, etc.
- J. The developer shall submit evidence the plat has been sent to other units of Government or Utility companies that require notification of the development, such as School District, Electric Company, Gas Company, Telephone Company, CATV Company, and any other entity designated by the Village Engineer.

#### SECTION 4.6 PRELIMINARY PLAT APPROVAL

- A. If all of the above requirements have been satisfied, the Village Clerk will present the preliminary plat to the Plan Commission at a duly called meeting thereof which must be held within 90 days from the date of the application or the filing by applicant of the last item of required supporting data, which ever date is later, unless the time is extendable mutual consent.

The developer or a responsible representative and the engineer or surveyor shall attend this meeting. The Plan Commission shall either:

1. Recommend to the Village Board of Trustees that it deny approval of the preliminary plat.
2. Recommend to the Village Board of Trustees that it approve the preliminary plat.
3. Recommend to the Village Board of Trustees that it approve the preliminary plat, subject to minor corrections or additions.

- B. If the Plan Commission recommends denial of approval of the preliminary plat, the reasons for the denial shall be clearly set forth and delivered to the developer.
- C. If the Plan Commission recommends approval of the preliminary plat, it shall be so executed at that time. The preliminary plat shall then be presented to the Village Board at their next regular meeting which must accept or reject said preliminary plat within 30 days of such meeting. After approval by the Village Board the developer shall then proceed with the final plat and subdivision engineering improvement plans and specifications.
  - 1. The approval of the preliminary plat shall be in effect for a period of one (1) year from the approval date. If the final plat and subdivision improvement plans and specifications have not been filed on or before this date, then the preliminary plat shall become null and void, unless said subdivision is developed in "phases" with the consent of the Village Board in accordance with Illinois Revised Statutes, Chapter 24, Section 11-12-8.
- D. If the Plan Commission recommends approval the preliminary plat subject to minor corrections or additions, the developer has fourteen (14) calendar days from the Plan Commission meeting date to make the corrections or additions and resubmit the preliminary plat to the plat officer. The preliminary plat shall not be presented to the Village Board until all corrections or additions are completed. The Village Board may accept or reject the plat, or it may accept it subject to minor corrections and additions. If it so conditionally accepts it, and those conditions are satisfied, the official signing of the preliminary plat shall occur at the next regular Village Board Meeting. If the conditions are not met then the plat is rejected and the developer shall resubmit the preliminary plat as required by this Ordinance.
- E. On the preliminary plat the following certificate shall appear:

PRELIMINARY PLAT APPROVAL

The Preliminary Plat entitled \_\_\_\_\_  
\_\_\_\_\_ has received a recommendation for preliminary approval by the Plan Commission of the Village of Philo, Illinois.

\_\_\_\_\_  
Chairman Date

\_\_\_\_\_  
Secretary Date

The Preliminary Plat has received approval by the President and Board of Trustees of the Village of Philo, Illinois.

\_\_\_\_\_  
President Date

\_\_\_\_\_  
Village Clerk Date

**SECTION 5.1 FINAL PLAT SUBMISSION**

- A. At any time within one (1) year after receiving preliminary plat approval, the developer shall submit to the Plat Officer seven (7) copies of the final plat fourteen (14) calendar days prior to any regular meeting of the Plan Commission. Also, the developer shall submit to the Village Engineer two (2) copies of the subdivision plans and specifications on the same date. If the developer does not file these documents fourteen (14) days prior to the meeting, the final plat shall not be considered at that meeting but will be tabled until the next regular meeting.
  
- B. Prior to approval of the final plat, the subdivider must submit to the Village Engineer and the Village Attorney the proposed owner's certificate with subdivision restrictions and covenants.

The Village may, depending upon the provisions of the restrictions and covenants and depending upon any waiver granted in the subdivision process, require that those covenants in which the Village has a public interest may not be amended or revoked by the developer or the property



owners without the written approval of the Village Board of Trustees. In that event, the initial covenants and restrictions shall contain a provision that such provisions of the covenants may not be amended, revoked or modified without the written approval of the Village Board of Trustees.

The subdivision plat shall not be approved until the Village Engineer and the Village Attorney have furnished their written approvals to the Village Board of Trustees of the subdivision owner's certificate with restrictions and covenants, subdivider's bond and bond security.

- C. The final plat shall contain all the information required by and conform to the standards of Section 5.2 and 5.3 of this Ordinance.

#### SECTION 5.2 GENERAL

- A. The name of the subdivision.
- B. The certificate of a Registered Land Surveyor.
- C. The date of preparation, scale and north arrow. The scale and size of the plat shall be such that photographic reduction to 16" x 17" will not impair the detail. Plats in several sections are permissible. The minimum scale shall be 1"=100'.
- D. The location and position of the subdivision indicated in each of the following ways:
  - 1. By quarter section, section, township, range, meridian, County and State.
  - 2. By distances and bearings from true or assumed north and angles with reference to a corner or corners established in the United States Public Land Survey.
  - 3. By a written legal description of the exterior boundaries of the land as surveyed and divided.
- E. The plat shall comply with the current Illinois State revised Statutes. Information which shall appear on the plat:
  - 1. Tributary drainage area.
  - 2. Location of subdivision relative to Corporate Limits.
  - 3. Consideration of surface water flow.
- F. The final plat shall be drawn with ink on either linen cloth or a stable plastic film.

### SECTION 5.3 DETAILED INFORMATION

- A. Boundary line of proposed subdivision indicated by solid heavy lines and the total acreage encompassed thereby. The plat shall clearly indicate all streets, alleys, blocks, lots, parcels, easements, and right-of-ways. Accurate angular and lineal dimensions shall be shown to describe and/or reproduce any of these features. All curved lines shall accurately give dimensions for the radius, chord length, chord bearing and arc length.
- B. The description and location of all subdivision and public land system survey monuments.
- C. A consecutive numbering system for all lots and blocks.
- D. Location and names of all existing or prior platted streets or other public ways, railroad and utility right-of-ways, parks and other public open spaces, permanent easements or prior platted lots within and adjacent to the subdivision.
- E. A graphic representation of the minimum setback lines on all lots and parcels, and a notation of the distance between such lines and the street line, or lot line.
- F. Iron pipes or other equivalent physical markers shall be placed at each lot corner. No pipe monument shall be less than 3/4 inch in diameter, I.P.S. weight water pipe at least 30 inches long or 1/2 inch, No. 4 reinforcement bars at least 30 inches long.

Iron pipe or 1/2 inch No. 4 reinforcement bars encased in concrete at least 4" x 4" x 30" shall be placed at the beginning and ending of all curves along the right-of-way, at all block corners, and at exterior corners of the subdivision. A minimum of 2 concrete monuments shall be placed in each subdivision.

- G. The total square footage for each lot shall be shown on the plat.

Iron pipe encased in concrete at least 4" x 4" x 30" or equivalent markers shall be placed at the beginning and ending of all curves and at all block corners.

### SECTION 5.4 ATTACHMENTS

- A. The final plat shall be accompanied by:
  - 1. Protective covenants, if any, if required.
  - 2. A notarized certification by Owner and by mortgage holder of record, of the adoption of the plat and the dedication of streets and other public areas, and any restrictions as to usage, buildings, occupancy, etc. See form attached to this Ordinance.

3. Certification from the County Clerk and Village Treasurer that all taxes and special assessments due on the property to be subdivided have been paid in full.
4. Additional Approvals or evidence of submittal from other units of Governments or Utility Companies that are required with the preliminary plat shall be submitted with the final plat.
5. Performance Bond or Assignment of Certificate of Deposit.

#### SECTION 5.5 FINAL PLAT APPROVAL

- A. If all of the above requirements have been satisfied, the Plat Officer will present the final plat to the Plan Commission at the next regular meeting. It is recommended that the Developer be present at this meeting. The Plan Commission shall make one of the following recommendations to the Village Board:
  1. Recommend that the Village Board deny approval of the final plat.
  2. Recommend that the Village Board approve the final plat.
  3. Recommend that the Village Board approve the final plat, subject to minor corrections or additions.
- B. If the Plan Commission recommends denial of approval of the final plat, the reason for denial shall be clearly set forth and delivered to the Developer.
- C. If the Plan Commission recommends to the Village Board approval of the final plat, it shall be so executed at that time. The original plat and seven (7) copies shall be executed by the Plan Commission. The Plat Officer shall then present the final plat to the Village Board at its next regular meeting. At the same Village Board meeting, the Village Engineer shall present the subdivision improvement plans and specifications. At that time, the Village Board shall approve or disapprove the final plat, and the plans and specifications, and shall clearly state their reasons for their actions. In the event the Village Board disapproves either the plat or the final plans and specifications, the Developer has one (1) year from the date of such disapproval to make the corrections and re-submit to the Village Board; otherwise, the prior approval of the Plan Commission and/or the approval of the Village Engineer shall become null and void. Such action by the Village Board must be taken within 60 days of filing the application for approval of the final plat or of filing required documents therefore, whichever is later.

On the Final Plat, the following certificate shall appear:

FINAL PLAT APPROVAL

The Preliminary Plat entitled \_\_\_\_\_  
\_\_\_\_\_ has a recommendation for (approval)  
(disapproval) by the Plan Commission of the Village of Philo, Illinois.

\_\_\_\_\_  
Chairman

\_\_\_\_\_  
Date

\_\_\_\_\_  
Secretary

\_\_\_\_\_  
Date

SECTION 5.6 VILLAGE BOARD ACTION

- A. The Village Board will not give the final approval to any proposed subdivision until:
  - 1. The Plan Commission has recommended approval or disapproval of the final plat.
  - 2. The Village Engineer has recommended approval or disapproval of the subdivision improvement plans and specifications.
  - 3. The Developer presents his Performance Bond or Assignment of Certificate of Deposit or corporate surety in the amount and form in accordance with the attachment to this Ordinance.
- B. The Village Board, after receiving recommendations from the Plan Commission and Village Engineer shall then consider the proposed subdivision.
  - 1. The following certificate shall appear on the Final Plat directly below the Plan Commission Certificate:

The Final Plat entitled \_\_\_\_\_ has received approval by the President and Board of Trustees of the Village of Philo, Illinois. This Plat shall be recorded with the Recorder of Deeds, Champaign County, Illinois, within one year of this date, otherwise the Plat shall become VOID.

(SEAL)

\_\_\_\_\_  
President Date

\_\_\_\_\_  
Clerk Date

**SECTION 5.7 ENGINEERING IMPROVEMENT PLANS AND SPECIFICATIONS**

The following certificate shall appear on the cover sheet of the Engineering improvement:

**APPROVAL BY THE VILLAGE OF PHILO**

The Plans and Specifications for \_\_\_\_\_ have received a recommendation for (approval) (disapproval) by the Village Engineer.

\_\_\_\_\_  
Village Engineer Date

\_\_\_\_\_  
Attest Date

The Plans and Specifications for \_\_\_\_\_ have received approval by the President and Board of Trustees.

\_\_\_\_\_  
President Date

\_\_\_\_\_  
Clerk Date

After approval of the Final Plat, plans and specifications by the Village Board, the Final Plat shall be recorded by the Plat Officer when the subdivider submits a written request to the Plat Officer that the plat be recorded and the correct recording fee is attached with the request. The Plat Officer shall record the plat within ten (10) days of the request.

**SECTION 6.1 PROCEDURES FOR RESUBDIVIDING AND REPLATTING  
RECORDED LOTS AND FOR VACATION OF PLATS**

All regulations, procedures and standards made applicable herein to original subdividing shall also apply to the resubdividing and replotting of a plat or parts thereof, as provided by these regulations.

- A. Procedure for Resubdivision - For any change in a map of an approved or recorded subdivision plat, if such change affects any street layout shown on such map, or area reserved thereon for public use, or any lot line, or if it affects any map or plan legally reached prior to the adoption of any regulations controlling subdivision, such parcel shall be approved by the Plan Commission and Village Board of Trustees by the same procedure, rules and regulations as for a subdivision.
- B. Procedure for Subdivisions Where Future Resubdivision Is Indicated - Whenever a parcel of land is subdivided and the subdivision plat shows one or more lots containing more than one acre of land and there are indications that such lots will eventually be subdivided into small building sites, the Plan Commission and Village Board of Trustees may require that such parcel of land allow for the future opening of streets and the ultimate extension of adjacent streets. Easements providing for the future opening and extension of such streets if any be made a requirement of the Plat.
- C. Vacation of Plats - Any plat or any plat of any plat may be vacated by owner of the premises, at any time before the sale of any lot therein, by a written instrument, to which a copy of such plat shall be attached, declaring the same to be vacated.

Such an instrument shall be approved by the Plan Commission and the Village Board of Trustees in like manner as plats of subdivisions. The governing body may reject any such instrument which abridges or destroys any public rights in any of its public uses, improvements, streets, or alleys.

Such an instrument shall be executed, acknowledged or approved, and recorded and filed, in like manner as plats of subdivisions; and being duly recorded or filed shall operate to destroy the force and effect of the recording of the plat so vacated, and to divest all public rights in the streets, alley, and public grounds, and all dedications laid out or described in such plat.

When lots have been sold, the plat may be vacated in the manner herein provided by all the Owners of lots in such plat joining in the execution of such writing.

## SECTION 7.1 SUBDIVISION STANDARDS

### A. General

1. The procedure for submitting the engineering plans and specifications is stated herein. The Village Engineer will not recommend approval of the plans and specifications to the Village Board until all of the information submitted is in accordance with the standards and procedures herein stated.
2. All engineering plans and specifications for any subdivision shall be prepared by a Registered Professional Engineer. Before the completed improvements are approved or accepted by the Village, such Engineer shall furnish the Village a completion certificate stating that such improvements comply with all the requirements of such plans and specifications. The form of the Engineer's Certificate is an attachment to this Ordinance.

The Engineer's Certificate must be accompanied by the appropriate testing data as specified in these documents.

The engineering plans and specifications referred to in the preceding paragraph shall, after certification by a Registered Professional Engineer and after the approval of the Village Engineer, constitute part of the official plan of the Village of Philo.

The Registered Professional Engineer who will certify the construction of the improvements shall not have an ownership interest nor be a regular employee of the Developer.

The Engineer shall furnish the Village Engineer three (3) sets of approved plans and specifications prior to starting any construction operations.

The plan sheets shall be 24 inches by 36 inches. The minimum graphic scale shall be 1" = 50'. The plans shall include the following items:

- a. Cover sheet project location and Professional Engineer's Seal and signature; also see "Procedures for Village Certificates required".
- b. Existing topography.
- c. Existing and proposed contours (interval not greater than 2 feet) and/or spot elevations on U.S. Geological Survey Datum.
- d. Street pavement and storm sewer plan.
- e. Street profile, storm sewer profile, and drainage swales.

- f. Erosion Control Plan.
- g. Water distribution plan, including valves, fire hydrants and fittings.
- h. Details.

The developer shall obtain approval and all necessary permits from other units of government, agencies, or entities that have jurisdiction or review authority over the project (Illinois Department of Transportation, Champaign County Highway Department, Illinois Environmental Protection Agency, Drainage District, etc).

B. Access

Provisions shall be made to grant access for future development of unplatted adjacent land at intervals of not more than one-quarter mile. This applies to utilities as well as streets.

C. Waivers

In the event the Developer proposes to deviate from these subdivision standards, the Developer's Engineer must submit, in writing, a request to the Village Engineer stating the degree of deviation and the reasons why such deviation is necessary or desirable. The deviation, or waiver, must be approved by the Plan Commission and the Village Board prior to the final plat approval and shall apply to that location and point in time only. The decision whether to grant any such waiver is solely in the discretion of the Village Board and no subdivider has any right or entitlement thereto. Waiver requests shall be submitted with the preliminary plat so that approval of both can be considered at the same time. If after preliminary plat approval, additional waivers are required, the developer may ask for approval of these additional waivers at the time of final plat and plan consideration.

D. Subdivider's Bonds

1. Construction Bond

- a. Amount of Bond. The subdivider must furnish, as a condition to approval of the final plat, a Construction Performance Bond in an amount equal to 120% of the estimated costs of the public improvements, including, but not limited to, roadways, water lines, sidewalks, and utility services in the subdivision in the form specified on Attachment 2. The amount of the estimated costs of public improvements involved shall be determined by the Village Board, upon the advice of the Village Engineer.
- b. Bond Security. Said bond must be guaranteed by an acceptable corporate surety, as approved by the Village



Board. In lieu of corporate surety, the subdivider may furnish a fully executed assignment of an unencumbered cash deposit solely in subdivider's name in a bank or savings institution in an amount equal to the amount of the bond as security for performance of said Bond, in the form specified on Attachment 2. A subdivider may also, in lieu of a corporate surety or assignment of a deposit, furnish an irrevocable letter of credit payable to the Village in that same amount, from a bank, and in a form acceptable to the Village Attorney.

- c. Reduction of Bond. The amount of the bond and the bond security may be reduced as the public improvements are constructed, if the subdivider's engineer submits a request therefore and proof of the value of the work completed. If the Village Engineer confirms that such work is completed, and agrees with the value thereof, and so recommends, the bond and surety may be reduced by the 120% of the value of the completed work, if the Board of Trustees determines to do so. Provided however, that the bond shall not be reduced to less than 25% of the estimated costs of such improvements until all work is complete and the required Maintenance Bond with security has been furnished to the Village.
2. Maintenance Bond - The subdivider must also furnish, as a condition to approval of the final plat, a Maintenance Bond in an amount equal to 25% of the estimated costs of the public improvements in said subdivision, in the form specified on Attachment 3 hereof, and with corporate surety thereon, as approved by the Village Board. In lieu of corporate surety, the subdivider may furnish a fully executed assignment of an unencumbered cash deposit solely in Subdivider's name in a bank or savings institution in an amount equal to the amount of the bond as security for the performance of said bond, or an irrevocable letter of credit payable to the Village, from a bank and in a form acceptable to the Village Attorney.
3. Construction of Improvements - No construction bond is required if the subdivider satisfactorily constructs all necessary public improvements before approval of the final plat. A maintenance bond would be required, however.

E. Notice

It shall be the duty of the Certifying Engineer to notify the Village Engineer and the specific Village Superintendent at least one (1) day in advance of any starting, suspended, resumption or completion of each phase of construction work. This article shall not apply to work suspended by reason of adverse weather conditions.

F. Inspection

The degree of engineering inspection during construction operations shall be 100% during storm sewer, water main, sidewalk, and pavement construction. The inspection shall be done by the Certifying Engineer or by a person working under the direction of the Certifying Engineer. All construction shall be done in accordance with the approved plans and specifications, with an inspector present as stated herein, or the Village Engineer or Village Inspector shall stop all construction operations.

G. As-Built Plans

After completion of the project and prior to acceptance by the Village Board, the Consulting Engineer shall furnish the Village Engineer three (3) complete sets of "as built" plans with each sheet clearly marked "as built" in the lower right hand corner. These plans shall indicate the final location of all improvements. Three (3) copies of the approved final plat shall accompany these drawings.

SECTION 8.1 IMPROVEMENTS

A. Streets – A public street or streets shall be provided to afford convenient access to all property within the Subdivision. Proposed streets shall be connected to existing street systems where possible. Private streets or alleys shall not be permitted.

1. Collector streets shall be spaced at one mile intervals and shall be placed at section lines. Collector streets shall have a dedicated street right-of-way of 80 feet.

Major streets shall be spaced at approximate 1/4 mile intervals between collector streets. Major streets shall have a dedicated street right-of-way of 80 feet.

All other streets are minor streets or cul-de-sac streets. Minor streets and cul-de-sac streets shall have a dedicated street right-of-way of 60 feet.

2. Minimum pavement widths for streets as measured from edge of pavement to edge of pavement shall be as follows:

Collector	36 feet
Major	30 feet
Minor	30 feet
Cul-de-sac	30 feet

All Developers are required to construct full pavement width unless the project property line is the centerline of the dedicated right-of-way in which case the Developer shall construct one-half of the required pavement width.

If additional pavement width and/or thicknesses are required, the Village will participate in the additional cost.

3. Pavement Grades shall be:
  - a. Minimum 0.40%
  - b. Maximum 8.00%
4. Radii at pavement intersections shall be 25 feet measured along the edge of pavement.
5. All cul-de-sacs shall have a minimum pavement radius of 50 feet (measured to edge of pavement). Right-of-way radius minimum 60 feet.
6. Horizontal curves in streets shall be permitted provided no curves shall be less than that approved by the Village Engineer as reasonably safe for traffic at the particular location of the curve. All horizontal curves shall have a minimum center line radius of 250 feet.
7. Street jogs with centerline offsets of less than one hundred twenty-five feet shall not be permitted if the same can be reasonably avoided.
8. Proposed streets which are obviously in alignment or continuation of existing streets already named shall bear the name of such existing streets. In no case shall the name for proposed streets duplicate existing names irrespective of the use of the suffix street, avenue, road, boulevard, drive, place, or court, or an abbreviation thereof, or minor variations in spelling.
9. Provisions shall be made to grant access for future development of unplatted adjacent land at intervals of not more than one-quarter mile.
10. Blocks shall not be less than four hundred feet nor more than eight hundred feet in length except as the Plan Commission considers necessary to secure efficient use of land or desired features of the street pattern.

In blocks six hundred feet or more in length, the Plan Commission may require a public crosswalk for pedestrian travel to extend entirely across the block at the location deemed necessary. The crosswalk shall be constructed of Portland Cement concrete. The width of the concrete shall be four feet, thickness 4 inches, and the crosswalk shall be located on a ten foot easement.

Blocks shall be wide enough to allow two tiers of lots, except where fronting on major streets or prevented by topographical

conditions or size of the property, in which case the Plan Commission will approve a single tier of lots.

11. Cul-de-sacs shall have a maximum length of 600 feet measured from the center line of the intersection street to the center of the turnaround, unless the topography of the land being subdivided, or the physical situation of that land, makes such a restriction impractical.
12. Where an existing street is adjacent to the subdivision, the subdivider shall improve the half of the street to conform to these standards, except where the existing street is a township road.
13. If any trees are proposed to be planted on any part of the subdivision devoted to public use, the species of trees and the location thereof shall be subject to the approval and direction of the Philo Plan Commission.
14. Street signs shall be erected at each street intersection within the subdivision. A detail of the street sign is attached to these standards.
15. Before final approval all pavements shall be cored for thickness by the Developer in the presence of the Village Engineer. Two cores shall be taken every 500 feet per lane unless deficiencies are encountered. Requirements in the event of deficient pavement thickness shall be as follows:
  - a. One inch or less deficiency will be accepted only in isolated areas.
  - b. Over one inch deficiency will be removed and replaced to the plan thickness or an asphalt seal coat constructed as approved by the Village Engineer.
16. The subgrade for all streets shall be prepared properly so that after compaction it will conform to the alignment, grade, and cross-section shown on the approved plans. Soft and unstable material that will not compact shall be removed and replaced with material approved by the Village Engineer. The entire subgrade shall be compacted to not less than 95 percent of the standard laboratory density.

## SECTION 8.2 BITUMINOUS SURFACE TREATMENT (RESIDENTIAL AREAS ONLY)

Bituminous Surface Treatment shall consist of a prime coat, two separate applications of a bituminous cover coat material and cover coat aggregate, and one bituminous seal coat and seal cover aggregate. Aggregate Base Course shall be Type B as described in Section 301 of "Standard Specifications for Road and Bridge Construction, State of Illinois, Department of Transportation". The guidelines as set forth in Section 403 of the above mentioned standards shall be

followed. The Aggregate Base Course thickness shall be 8 inches. See Standard Drawing No. 1 attached to this document. This type of pavement will not be allowed in commercial or industrial zoned areas. Provided further that the Village Engineer may approve a suitable substitute for said base course materials in unusual circumstances.

**SECTION 8.3 COMMERCIAL AND INDUSTRIAL STREETS**

Areas zoned or planned as Commercial or Industrial Areas shall have pavement constructed as follows:

**A. Width**

The widths shall be determined by an analysis of the projected traffic. The analysis shall be presented to the Village Engineer for his review and approval. Minimum pavement width to be 32 feet as measured face to face of curbs.

**B. Curb and Gutter**

Combination concrete curb and gutter shall be required on both sides of all proposed streets. The shape of the curb and gutters shall conform to that in use by the Department of Transportation, State of Illinois.

**C. Pavement Type and Thickness**

<u>Type</u>	<u>Thickness</u>
Portland Cement Concrete	7 inches
Bituminous Concrete Surface Course	3 inches
Cement Aggregate Mixture Base Course	10 inches
Bituminous Concrete Surface Course	3 inches
Bituminous Base Course	10 inches
Bituminous Concrete Surface Course	3 inches
Soil Cement Mixture Base Course	11 inches
Bituminous Concrete Surface Course	3 inches
Portland Cement Concrete Base Course	6 inches

**D. Concrete Pavement Construction Requirements**

1. Longitudinal construction joints shall be tied with number four (#4) deformed tie bars, thirty inches (30") long at thirty inch (30") intervals. Sawed contraction joints at twenty foot (20') intervals.
2. The concrete shall meet the following requirements:

- a. Have compressive strength of three thousand five hundred (3500) pounds per square inch in fourteen (14) days or a modulus of rupture equal to six hundred fifty (650) pounds per square inch in fourteen (14) days.
  - b. Have a minimum of six (6) bags of cement per cubic yard of concrete.
  - c. Have a workable slump approved by the Village Engineer, but in no instances greater than three (3) inches.
  - d. Mix shall be submitted to the Village Engineer for approval prior to beginning construction operations; test data must accompany the mix proportions to verify the strength of the proposed mix.
  - e. Be field tested for strength by the Certifying Engineer or independent testing laboratory during construction by taking beam or cylinder specimens at the minimum rate of two (2) per 500 feet per lane or two (2) per day, whichever is greater.
  - f. Be cured by standard procedures, as approved by the Village Engineer.
  - g. Be finished with a finishing machine approved by the Village Engineer, the machine shall be self propelled, capable of striking off, consolidating and finishing the concrete of the consistency required to the proper crown and grade.
  - h. Be air-entrained (5% to 7%) and field tested to verify this air-entrainment.
3. The subgrade shall be prepared properly so that after compaction it will conform to the alignment, grade, and cross-section shown on the approved plans. Soft and unstable material that will not compact shall be removed and replaced with material approved by the Village Engineer. The entire subgrade shall be compacted to not less than 95 percent of the standard laboratory density.

E. Bituminous Pavement Construction Requirements

1. The Bituminous Concrete Surface Course shall meet the following requirements:
  - a. Minimum Marshall Stability of 1700 pounds.
  - b. Current Department of Transportation Standard Specifications except the three-wheel roller will not be required if the 93 percent compaction can be obtained.

- c. Can be constructed in 1-1/2 inch lifts.
  - d. The mix design shall be submitted to the Village Engineer for approval prior to beginning construction operations.
  - e. Two field density tests must be taken for each day's construction by an independent testing laboratory; the test results must be submitted to the Village Engineer for approval.
2. The Bituminous Base Course shall meet the following requirements:
- a. Minimum Marshall Stability of 1,700 pounds.
  - b. Be constructed in maximum lift thickness of 6 inches and minimum lift thickness of 3 inches.
  - c. Current Department of Transportation Standard Specifications, latest edition.
  - d. The sources of material and blending proportions shall not be changed during the progress of the work without written permission from the Village Engineer.
  - e. The mix design shall be submitted to the Village Engineer for approval prior to beginning construction operation.
  - f. General Conditions: The bituminous aggregate mixture shall be constructed only when the temperature in the shade is above 40 degrees Fahrenheit. In specific cases, the Village Engineer may order, in writing, waiver of this limitation.
  - g. The density of each of the finished layers of bituminous aggregate mixture shall be obtained from specimens furnished by the Contractor. Specimens shall be cut by the Contractor from the finished layers with a core drill. The diameter of a specimen shall in no case be less than 3-7/8 inches nor more than 4 inches. Two specimens shall be taken for each day's run for each layer. The Contractor shall remove the specimens at locations designated by and in the presence of the Engineer and transport them to the testing laboratory. Extreme care shall be taken to avoid damage to the specimens. The holes caused by the removal of the specimens shall be refilled immediately with bituminous aggregate mixture meeting these specifications, compacted and finished to the satisfaction of the Village Engineer. The density tests shall be conducted by an independent testing laboratory.

3. The Cement Aggregate Base Course shall meet the following requirements:

- a. Minimum 7-day compressive strength of 650 pounds per square inch.
- b. The design mix shall be submitted to the Village Engineer for approval prior to beginning construction operations.
- c. Current Department of Transportation Standard Specifications for Road and Bridge Construction.
- d. Only Types I & IA Portland Cement shall be used.
- e. The aggregate shall meet the following gradation requirements:

Passing 1 inch sieve . . . . .	100%
Passing 1/2 inch sieve . . . . .	.80 + 20%
Passing No. 4 sieve . . . . .	.63 + 8%
Passing No. 8 sieve . . . . .	.43 + 18%
Passing No. 200 sieve . . . . .	13 + 7%

A local material not meeting the above gradation may be used if permitted by the Village Engineer.

- 1. If approved by the Village, the material may be produced by blending aggregates from two sources, provided the method of blending results in a uniform product. The components of a blend need not be of the same kind of material.
  - 2. The source of materials shall not be changed during the progress of the work without written permission from the Village Engineer.
- f. General Conditions: The cement aggregate base course shall be placed only when the temperature of the subgrade, measured to three inches below the surface, is above 50 degrees Fahrenheit and the air temperature in the shade is above 40 degrees Fahrenheit.
  - g. Mixing: The constituents of the mixture shall be accurately proportioned and thoroughly mixed in a mechanical mixer at a central mixing plant. The control of the mixture shall be of such accuracy that the quantity of cement shall be within +0.3 percent of the design quantity based on the weight of the dry aggregate.

The mixing devices for proportioning the mixture, either by volume or by weight, shall be of such accuracy that the



proportions of the mixture will be maintained within the tolerance set forth in this special provision. The equipment used must be provided with means, meeting with approval of the Village Engineer, for calibration and check tests of the measuring devices.

In all plants, the water shall be proportioned by weight or by volume and there shall be means by which the Village Engineer may readily verify the amount of the water per batch or the rate of flow for continuous mixing.

The Contractor shall provide a platform scale and make arrangements for the use of a certified truck scale for calibration and periodical check tests of the feeders or measuring devices as needed during production.

On continuous mixing plants aggregate feeders that are mechanically driven shall be directly connected with the drive on the cement feeder.

The mixer shall be capable of producing a uniform mixture. Mixing operations shall be continued until all ingredients are distributed evenly throughout the mixture and a uniform mixture, free of segregation, satisfactory to the Village Engineer, is obtained. The mixer shall be capable of discharging the mixture without undue segregation.

The moisture content at the time of mixing shall be such that the moisture content at the time of compaction will be at optimum required, plus or minus one percent.

- h. Placing and Compacting Cement Aggregate Base Course: The construction methods for Sub-Base Granular Material, Type A, as stipulated in the Standard Specifications shall govern insofar as they apply, to the construction of the cement aggregate base course, except as hereinafter stated. Reference to granular material in Section 213 shall be construed to include cement aggregate base course.

The cement aggregate base course shall be spread for the full lane width. Depositing and spreading operation shall be conducted so that the total time elapsing from the time the water is added to the mixture until compaction is started will be less than 60 minutes.

Prior to the beginning of compaction, the mixture shall be in a loose condition. The loose mixture then shall be uniformly compacted to the specified density within two (2) hours. During compaction operations, shaping may be required to obtain uniform compaction and required grade and cross section.

The cement aggregate base course shall be constructed in three approximately equal layers. The first layer shall be maintained in a moist condition and the upper 1/2 inch shall be scarified prior to the placing of the succeeding layer.

Any portion of the cement aggregate base course that has a density of 5 pounds or more below the standard dry density determined as specified shall be corrected or replaced to meet these specifications. The density shall be determined by an independent testing laboratory in accordance with the standard Methods of Test for the Field Determination of Density of Soil In-Place, AASHTO Designation: T 147. One density test per 100 square yards is required.

The type, size, and number of compactors, and the rate of their operation, shall be such that the section being processed will be compacted within 2 hours of the time the water is added to the mixture.

The cement aggregate base course may be salvaged.

- i. Finishing: When initial compaction of the cement aggregate base course is nearing completion, the surface shall be shaped to the required lines, grades, and cross sections, and compaction continued until uniform and adequate compaction is attained. The moisture content of the surface material shall be maintained at or slightly above its optimum during all finishing operations and until curing material is applied.
- j. Curing: The cement aggregate base course shall be protected and covered for 7 days as provided in Article 303.14 of the Standard Specifications, except that the covering material shall be liquid asphalt RC-250, RS-2, or tar RT-4. Not more than 24 hours shall elapse after completion of the finishing operations before the liquid asphalt or tar is applied upon the surface. References in Article 303.14 to soil-cement base course shall be construed to include cement aggregate base course. At least three days shall elapse after completion of the finishing operations before a bituminous surface treatment or bituminous concrete binder and surface course is placed.
- k. Construction Joints: At the end of each day's construction, or when construction operations are delayed or suspended and the Engineer so orders, a straight transverse construction joint shall be formed by cutting back into the

completed work to form a vertical face. Damage to completed work shall be avoided.

- I. Maintenance: The Contractor shall maintain, at his own expense, the entire base course in a manner satisfactory to the Engineer until the surface base course has been completed. Maintenance shall include immediate repairs of any defective or damaged portions of the base course. Repairs or replacements shall be made in such a manner as to insure restoration of a uniform surface and durability of the portion repaired or replaced.

The Contractor shall also remove and replace, at his own expense, any cement aggregate base course which is unsatisfactory due to its being placed over excessively wet or otherwise unstable subgrade; damaged by rain, freezing or other climatic conditions; damaged by traffic; or which is unsatisfactory due to failure to comply with any of the requirements specified herein.

- m. Traffic: Completed portions of cement aggregate base course may be opened to local traffic and to construction equipment, and to all traffic after the 7-day curing period, provided the base has hardened sufficiently to prevent marring or distorting of the surface by equipment or traffic and provided the curing is not impaired.

4. The Soil Cement Mixture Base Course shall meet the following requirements:

- a. Minimum 7-day compressive strength of 400 pounds per square inch.
- b. The design mix shall be submitted to the Village Engineer for approval prior to beginning construction operations.
- c. Comply with Section 303 of the Standard Specifications.
- d. Field density tests shall be taken every 100 square yards by an independent testing laboratory.

5. The Portland Cement Concrete Base Course shall meet the following requirement:

- a. Meet all requirements of Section 304 of the Standard Specifications.

## SECTION 9.1 STORM DRAINAGE SYSTEM

### A. Design, Collection System

1. All storm sewer systems shall be designed for a five (5) year frequency storm. The minimum pipe diameter shall be twelve (12) inches. The system shall have a free outlet.
2. The maximum distance for overland flow of storm water runoff shall be six hundred (600) feet.
3. All manholes and catch basins shall be constructed in accordance with the attached standard details. (Standard Drawing No. 6 through 9).
4. The maximum distance between manholes shall be as follows:  
The sewer shall be constructed in a straight line between manholes.  
  
12" - 24" diameter - 350 feet  
over 24" diameter - 500 feet
5. Trench backfill requirements shall conform to the applicable portions of the "Standard Specifications for Road and Bridge Construction, State of Illinois, Department of Transportation".
6. All design calculations must be submitted to the Village Engineer for approval.
7. The type of sewer pipe shall be:
  - a. Concrete and/ or reinforced concrete pipe.
  - b. Bituminous coated corrugated steel culvert pipe.
  - c. Bituminous coated corrugated aluminum alloy culvert pipe.
  - d. High density polyethylene pipe which has a corrugated exterior and a smooth interior, all in accordance with AASHTO Specification M294, Type S.
8. The strength requirements of the sewer pipe shall conform to the requirements of the "Standard Specifications for Road and Bridge Construction, Department of Transportation". The appropriate tests must be submitted to the Village Engineer to verify the strength of the pipe used.
9. Surface drainage will be permitted for storm water where cost estimates show storm sewers are not economically feasible and topographic conditions indicate there will be no difficulty from this method of disposal of storm water.

10. All roadside culverts shall be designed for a Five (5) year frequency storm.

The minimum culvert size shall be as follows:

Street culverts 15" diameter minimum  
Driveway culverts 10" diameter minimum

B. Construction

All construction requirements shall conform to the applicable sections of the "Standard Specifications for Road and Bridge Construction, Department of Transportation".

The developer shall take necessary precautions to prevent sediments and debris from entering existing storm sewers. If during construction sediments and debris are allowed to enter the existing storm sewers as a result of the failure of the developer to take the necessary preventative action, he shall be required to clean and remove the sediments and debris from the sewers.

Existing field tile encountered during construction shall be connected to the new storm sewer system where possible. If it is not possible to connect the field tile to the new sewer system the existing field tile shall be routed to lie within utility easements or within the public right-of-way.

The developer shall incorporate acceptable erosion control management during construction of the development. This shall include both temporary and permanent steps intended to prevent erosion and to protect downstream landowners.

C. Requirements Detention Basins

1. A combination of storage and controlled release of storm water is required for all:
  - a. Nonresidential developments greater than two (2) acres in area; or less than two (2) acres with greater than 50% impervious area.
  - b. Residential developments greater than five (5) acres in area; or less than five (5) acres with greater than 50% impervious area.

D. Design Detention Basins

1. Detention ponds shall conform to the following criteria:
2. The controlled release rate of storm water runoff from the proposed development shall not exceed the existing "safe" storm drainage capacity of the natural downstream outlet channel or storm water system.

3. A channel system shall be designed with adequate capacity to convey through the development the storm water runoff from all tributary upstream area, assuming development of the upstream areas.
4. The detention storage volume to be provided will be calculated on the basis of the 100-year storm, for any and all duration, as published by a recognized agency. This volume of storage shall be provided for the fully developed watershed that is tributary to the area designed for detention purposes. The storm water release rate shall be considered when calculating the storm water storage capacity and the control structure designed to maintain a relatively uniform flow rate regardless of the depth of storm water in the storage area.
5. The release rate of storm water from the detention basin shall not exceed the natural, undeveloped runoff rate computed for a 2-year storm with a maximum runoff coefficient of  $C = 0.15$ .
6. Residential developments of five (5) acres or less and a nonresidential development of two (2) acres or less must have an adequate outlet approved by the Village Engineer. If the outlet is not adequate, then detention, as determined by the Village Engineer will be required to store that portion of the runoff exceeding the outlet capacity.
7. Maximum side slopes for detention basins shall be 4 to 1.
8. Design calculations for storm detention shall be submitted to the Village engineer for review and approval.
9. Dry Basins shall have a minimum bottom slope of 2%, except slopes of less than 2% will be allowed when underdrains are installed.

E. Erosion and Sedimentation Control

1. Erosion control measures shall be prepared in accordance with the standards and requirements of the Illinois Environmental Protection Agency.

The subdivider shall incorporate erosion control management during construction of the development in accordance with the erosion control plan. This shall include both temporary and permanent steps intended to prevent erosion and to protect downstream landowners.

The subdivider shall obtain all required Illinois Environmental Protection Agency permits.

2. The control plan required shall contain such information needed to determine soil erosion, sedimentation, and runoff control throughout all phases of construction. The plan shall indicate the erosion control plan to be in effect upon completion of development of the site.
3. A topographic map of the site location, including the contiguous properties, existing drainage patterns and watercourses affected by the proposed development of the site and the existing vegetative cover.
4. A plan of the site showing:
  - a. Limits of natural floodplain(s), based on a 100-year flood, if any.
  - b. The proposed phasing of development of the site, including stripping and clearing, rough grading and construction, and final grading and landscaping. Phasing should identify the estimated duration of exposure of cleared areas and the sequence of clearing, installation of temporary sediment control measures, installation of storm drainage, paving streets and parking areas, and establishment of permanent vegetative cover.

## SECTION 10.1 WATER DISTRIBUTION SYSTEM

### A. Distribution System

All subdivisions shall be provided with a public water system. Aqua-Illinois is the owner and operator of the public water system in the Village of Philo, Illinois. All design, approval, materials, construction and acceptance shall be in accordance with Aqua-Illinois rules and regulations.

### B. Fire Hydrants

1. Fire hydrant shall be installed throughout the entire distribution system. The hydrant spacing shall provide for hose lines not exceeding 350 feet to a house. Hydrants along the street shall be at a maximum 500 foot interval.
2. All fire hydrants shall be equipped with an auxiliary valve located between the main and the hydrant. See attached detail.
3. All fire hydrant leads shall be a minimum six (6) inch diameter.
4. All fire hydrants shall have a seven (7) inch barrel, two (2) two and one-half (2-1/2) inch hose connections, and one (1) four and one-half (4-1/2) inch pumper connection. Threads shall match those presently in use for the local Fire Department.

5. All fire hydrants shall be dry-barrel type designed for 150 pounds per square inch working pressure conforming to AWWA C 502 with valve opening at least 5 inches in diameter. Outlets shall have American National fire hose coupling threads. All working parts shall be bronze. Hydrants shall be latest stock pattern produced by manufacturer. Hydrants shall open counterclockwise. The hydrant type shall be approved by the Village Engineer and Philo Fire Department.

C. Wells

Where the subdivider is proposing a development outside and not contiguous to the corporate limits and can show by cost estimates that it is not economical to connect a public water system (taking into account the cost of installing individual wells and their maintenance costs), he shall indicate that the lots are of adequate size to permit the construction of a well on each lot. Location of wells (separation of frame from buildings, lot lines, septic systems, etc.) shall be in accordance with Illinois Department of Public Health requirements. The well shall be situated clear of any driveway, parking area or other source of contamination. There shall not be any future cross connections between the well system and any public distribution system. The minimum lot size shall be in accordance with the Champaign County Zoning Ordinance.

The Village is not in any case, required to allow individual wells, but may, in its discretion, based upon the foregoing factors, all public safety considerations, and the advice of the Village Engineer, approve individual wells for subdivision lots, on whatever terms the Village deems appropriate. Otherwise, all subdivisions must have public water system hook-up as a condition of approval.

SECTION 11.1 SANITARY DISPOSAL FACILITIES

A. Minimum lot area shall be as follows:

1. Lots within the Village Corporate Limits served by the Village public water system and private sewage disposal systems shall have lot areas required by the Village Zoning Ordinance.
2. Lots outside the Village Corporate Limits shall have a lot area in compliance with the Champaign County, Illinois, Zoning Ordinance.

B. Connection to Village Storm Drainage Facilities

1. Septic tank and seepage field shall not be connected to the Village storm drainage facilities.
2. Mechanical or aeration sewage treatment systems requiring a connection to the Village drainage facilities shall obtain approval



from the Village before connection to said Village drainage facilities.

- C. The area used for seepage field shall not be under any proposed driveways, parking areas, buildings, nor on public property for streets or easements.
- D. Private sanitary disposal systems shall be submitted to the Champaign County Public Health District for review, approval and permitting. All private sanitary disposal systems shall be designed and constructed in accordance with said Public Health District rules and regulations.

## SECTION 12.1 SIDEWALKS

### A. General

1. Sidewalks shall be installed on both sides of all public streets and shall run to the back of the curb or to the edge of the pavement, if there is no curb at each corner lot. A supplemental bond and/or different arrangements may be requested in writing by the subdivider to the Village Board of Trustees. The Village Board of Trustees may, in its discretion, grant such requests, if the public interest is protected.
2. All sidewalks along streets shall be installed in public right-of-way. The back of the sidewalk shall be 1 foot inside the right-of-way, unless, for good cause shown, a variance in location is approved by the Village Board of Trustees. If roadway ditches are proposed the sidewalk shall be located in an easement as shown on Standard Drawing No. 1.
3. The Village Board of Trustees may waive the requirement that the subdivider install sidewalks in all subdivisions except those restricted to multifamily apartment developments, commercial or industrial areas.
4. Public crosswalks shall be located within the 10 foot easement as directed by the Village Engineer. This location shall be dependent upon the location of proposed utilities within the same easement.
5. All proposed sidewalks abutting streets shall be ramped with a nonslip surface (heavy broom finish) so that the street and sidewalk blend to a common level, enabling persons in wheelchairs to travel freely.
6. Sidewalks shall be installed by subdivider upon completion of construction on a lot.

### B. Design

1. All sidewalks shall be 4 foot in width.

2. All sidewalks shall be 6 inches thick.
3. Premolded expansion joints shall be placed at 50-foot intervals and at all curb intersections or intersections with other permanent structures.
4. All sidewalks shall be hand-grooved at 5-foot intervals, and edged with edging tool.

C. Construction

All sidewalks shall be concrete and shall conform to Section 624 of the Standard Specifications.

1. A minimum compressive strength shall be 3,500 psi in 28 days or a modulus of rupture equal to 650 psi in 14 days.
2. Be field tested as stated, at the rate of two specimens per 1200 lineal feet or per day, whichever is greater.
3. Be hand finished or machine finished in accordance with Section 624.07 of the Standard Specifications.
4. The subgrade shall meet the requirements set forth in Section 624.05 of the Standard Specifications.

SECTION 13.1 CHANGES AND AMENDMENTS OF REGULATIONS

The Plan Commission and Village Engineer shall from time to time prepare and recommend in writing to the Village Board such changes or additions to the provisions and regulations herein contained for subdivision control as may be deemed necessary or advisable. Such changes or additions shall become effective after their adoption by the Village Board by its passage of an amendment to this Ordinance as provided in Section 17.1 hereof. The Village Board itself can propose and adopt amendments as provided in Section 17.1.

SECTION 14.1 BUILDINGS WITHIN PROPOSED MATOR STREET EXTENSIONS

After the effective date of this Ordinance, no permanent building or structure shall be erected within the extended street line of proposed extensions of major streets.

SECTION 15.1 PENALTY- INJUNCTION

Whoever shall violate any of the provisions of this Ordinance shall be guilty of a misdemeanor and shall be fined not less than fifty (\$50.00) dollars and not more than five hundred (\$500.00) dollars for each offense. Each day the violation continues shall be deemed a separate expense.

In addition, any violation shall be subject to injunction enjoining further violations and mandatorily enjoining compliance by removal of existing violations.

The Village may seek injunctive relief together or separately from any penal sanction.

#### SECTION 16.1 VARIATIONS

Whenever the tract to be subdivided is of such unusual size or shape or is surrounded by such development or unusual conditions that the strict enforcement of the regulations would entail practical difficulties or unnecessary hardships, the Village Board by resolution, after report by the Plan Commission, may vary or modify them in such a way that the Subdivider is allowed to develop his property in a reasonable manner, but at the same time, the public welfare and interests of the Village and County are protected and the general intent and spirit of the regulations preserved.

#### SECTION 16.2 RECORDING DEED PROHIBITED WITHOUT COMPLIANCE

In accordance with State Law, no deed or other instrument of transfer of real property in the Village limits or within the area of subdivision control thereof, currently one and one-half miles, shall be accepted by the County Recorder for record unless said deed or other instrument of transfer is to a lot or parcel platted and on file or accompanied with a plat approved by the Village Board.

#### SECTION 16.3 SALE OR TRANSFER PROHIBITED WITHOUT COMPLIANCE

No person owning land composing a subdivision, nor his agent, shall transfer or sell or agree to sell any lot or parcel of land located within such subdivision by reference to, or exhibition of, or by any other use of a plat of such subdivision, before such plat has been approved, filed and recorded as provided in this Ordinance. The description of such lot or parcel by metes and bounds in any contract or instrument of transfer or other document used in the process of selling or transferring same shall not exempt such Owner or Agent from the penalties provided herein. Further, any subdivision of land must comply with this ordinance. Any conveyance or contract that effects a subdivision without compliance shall be illegal and null and void.

#### SECTION 16.4 NO BUILDING OR OCCUPANCY PERMIT WITHOUT COMPLIANCE

No building or occupancy permit shall be issued for any lot hereafter platted unless the plat including such lot has been approved, filed and recorded in accordance with the requirements of this Ordinance.

#### SECTION 17.1 AMENDMENTS

The Village Board may from time to time amend this Ordinance through the following procedure, and in accordance with applicable state law:

1. The Plan Commission shall hold a public hearing on the proposed amendment. Notice of the public hearing shall be published in a newspaper of general circulation in the Village at least one time, at least fifteen (15) days prior to the hearing.

2. Following the public hearing, the proposed amendment may be recommended as presented or in modified form or recommended for rejection by the Plan Commission.
3. Following its adoption of a recommendation, the Plan Commission shall certify such recommendation to the Board of Trustees for its consideration.
4. The Board of Trustees may reject the amendment, may return the proposed amendment, or may by ordinance adopt the amendment submitted by the Plan Commission.
5. Following adoption by the Board of Trustees, the adopted amending ordinance shall be filed in the office of the Village Clerk. The Village Clerk shall file with the County Recorder of Champaign County a copy of such amending ordinance.

Before any action shall be taken as provided in this section, any private party or parties proposing an amendment to this Ordinance shall deposit with the Village Treasurer the sum of One Hundred dollars (\$100) to cover the approximate cost of this procedure, and under no condition shall said sum or any part thereof be refunded for failure of said change to be adopted by the Board of Trustees.

#### SECTION 18.1 SEVERABILITY

If any provision(s) of this Ordinance shall be held to be unconstitutional, or invalid for other reasons, such unconstitutionality or invalidity shall not affect the validity or the remaining provisions of this Ordinance.

#### SECTION 19.1 PUBLICATION

This ordinance shall be published in pamphlet form pursuant to the provisions of Section 5/1-2-4 of Chapter 65, Illinois Compiled Statutes.

SECTION 20.1 EFFECTIVE DATE (SUBDIVISION ORDINANCE OF 1996)

This ordinance shall be effective after its passage, approval, and publication, as provided by law.

Passed and approved the 15<sup>th</sup> day of May, 1996.

/S/ Jean McCormick  
President of Board of Trustees

ATTEST:

/S/ Eileen Painter  
Village Clerk

SECTION 20.1 EFFECTIVE DATE (2005 AMENDING ORDINANCE)

The 2005 amendments to the Village of Philo Subdivision Ordinance shall be effective on January 1, 2006, [and shall be published in pamphlet form].

Passed and approved the 7<sup>th</sup> day of December, 2005.

/S/ Craig M. Eckert  
President of Board of Trustees

ATTEST:

/S/ Judy A. Kirby  
Philo Village Clerk

ENGINEER'S CERTIFICATE

STATE OF ILLINOIS            )  
  ) S.S.  
COUNTY OF CHAMPAIGN    )

I, \_\_\_\_\_ being a registered Professional Engineer in the State of Illinois , registration number \_\_\_\_\_, do hereby certify that \_\_\_\_\_  
\_\_\_\_\_ (the Project) was constructed in substantial accordance with the Plans and Specifications as approved by the Village of Philo, Illinois.

I further certify that all construction operations were inspected by me or someone under my supervision and that the construction performed is satisfactory and in substantial accordance with the Plans and Specifications as approved by the Village of Philo, Illinois.

Signed and Sealed this \_\_\_\_\_ day of \_\_\_\_\_, \_\_\_\_\_.

(SEAL) \_\_\_\_\_

CONSTRUCTION PERFORMANCE BOND

KNOW ALL MEN BY THESE PRESENTS, that \_\_\_\_\_  
\_\_\_\_\_ as Principal, and  
\_\_\_\_\_ with authority to do  
business in the State of Illinois, as Surety, are firmly bound unto the VILLAGE OF  
PHILO, State of Illinois, in the penal sum of lawful money of the United States, well and  
truly to be paid unto said VILLAGE OF PHILO for the payment of which we bind  
ourselves, our successors and assigns, jointly and severally by these presents:

THE CONDITION OF THE FOREGOING OBLIGATION is such that:

WHEREAS, the VILLAGE OF PHILO has approved, or will approve, the  
Principal's proposal to construct a \_\_\_\_\_  
known as \_\_\_\_\_ the plans and  
specifications of which are on file in the office of the Village Engineer of the VILLAGE OF  
PHILO and are referred to herein and made a part hereof, whereby said Principal has  
promised and agreed to construct said in accordance with applicable laws and with  
applicable ordinances and codes of the VILLAGE OF PHILO.

NOW, THEREFORE, the condition of the above obligation is that the Principal  
shall:

- (1) Perform and complete, or cause to be performed and completed, all work  
and improvements related to the construction of said \_\_\_\_\_  
\_\_\_\_\_ in accordance with said plans  
and specifications and in accordance with applicable laws and with  
applicable ordinances and codes of the VILLAGE OF PHILO.
- (2) Complete or cause to be completed, within two (2) years, from the date

of acceptance of this bond, said \_\_\_\_\_

in accordance with said plans and specifications and in accordance with applicable laws and with applicable ordinances and codes of the VILLAGE OF PHILO.

If said conditions are satisfied, this Bond shall be void; otherwise, said Bond is to remain in full force and effect.

DATED THIS \_\_\_\_\_ day of \_\_\_\_\_, \_\_\_\_\_.

_____ Principal	_____ Surety
_____ Attest	_____ Attest
_____	_____



STATE OF ILLINOIS            )  
  ) S.S.  
COUNTY OF CHAMPAIGN    )

I, the undersigned Notary Public in and for the County and State aforesaid, do hereby certify that \_\_\_\_\_

\_\_\_\_\_, personally known to me to be the \_\_\_\_\_

and personally known to me to be the person(s) whose name(s) is subscribed to the foregoing instrument as \_\_\_\_\_

\_\_\_\_\_ appeared before me this day in person and severally acknowledged that \_\_\_\_\_ signed the said instrument as Principal, as \_\_\_\_\_ free and voluntary act.

GIVEN under my hand and official seal this \_\_\_\_\_ day of \_\_\_\_\_, \_\_\_\_\_.

\_\_\_\_\_

STATE OF ILLINOIS            )  
  ) S.S.  
COUNTY OF CHAMPAIGN    )

I, the undersigned Notary Public in and for the County and State aforesaid, do hereby certify that \_\_\_\_\_

\_\_\_\_\_, personally known to me to be the \_\_\_\_\_

and personally known to me to be the person(s) whose name(s) is subscribed to the foregoing instrument as \_\_\_\_\_

\_\_\_\_\_ appeared before me this day in person and severally acknowledged that \_\_\_\_\_ signed the said instrument as Surety, as \_\_\_\_\_ free and voluntary act.

GIVEN under my hand and official seal this \_\_\_\_\_ day of \_\_\_\_\_, \_\_\_\_\_.

\_\_\_\_\_

ASSIGNMENT OF CERTIFICATE OF DEPOSIT

To \_\_\_\_\_

Bank Name

\_\_\_\_\_

FOR VALUE RECEIVED, I/we hereby assign to the Village of Philo, Illinois, my/our certificate of deposit no. \_\_\_\_\_ as security for Performance Bond with the Village of Philo, in the amount of

\_\_\_\_\_

\_\_\_\_\_

(\$ \_\_\_\_\_ ) Dollars.

The assignment shall be a continuing one and shall be effective for any renewals of the above until said bond is entirely discharged and the Village of Philo is hereby authorized to cash or otherwise dispose of said certificates.

DATED this \_\_\_\_\_ day of \_\_\_\_\_, \_\_\_\_\_.

\_\_\_\_\_  
Subdivider

Witnessed by:

\_\_\_\_\_

\_\_\_\_\_

The Signatures as shown above compare correctly with our files. Present  
Balance is \_\_\_\_\_ (\$ \_\_\_\_\_) Dollars.

Above assignment has been properly recorded on register.

DATED this \_\_\_\_\_ day of \_\_\_\_\_, \_\_\_\_\_.

\_\_\_\_\_  
Bank Official

\_\_\_\_\_  
(Title)

MAINTENANCE BOND

KNOW ALL MEN BY THESE PRESENTS, that we \_\_\_\_\_  
\_\_\_\_\_ as Principal,  
and \_\_\_\_\_ with authority to do  
business in the State of Illinois, as Surety, are firmly bound unto the Village of Philo,  
State of Illinois, in the penal sum of which is \_\_\_\_\_ of the actual cost of the  
construction of the public facilities \_\_\_\_\_  
\_\_\_\_\_

known as lawful money of the United States, well and truly to be paid unto said Village of  
Philo for the payment of which we bind ourselves, our successors and assigns, jointly  
and severally by these presents:

THE CONDITION OF THE FOREGOING OBLIGATION is such that:

WHEREAS, the said Principal has completed the work above described:

and

WHEREAS, the work has received final acceptance by the Village Engineer of  
the Village of Philo; and

WHEREAS, the Principal is under contract to the \_\_\_\_\_,  
the owner and developer of said \_\_\_\_\_, to guarantee  
maintenance of the above mentioned public facilities in accordance with applicable laws  
and with applicable ordinances and codes of the Village of Philo, for a period of one year  
after final acceptance by the said Village.

NOW, THEREFORE, in case said Principal shall maintain the public facilities  
herein described for a period of one (1) year after said final acceptance of said facilities  
by the Village of Philo, then this obligation is to be void; otherwise, this obligation shall  
remain in full force and effect and only that portion of the bond shall be refunded to the

Principal which is not required for reimbursement for amounts expended in correcting defective facilities.

DATED this \_\_\_\_\_ day of \_\_\_\_\_, \_\_\_\_\_.

\_\_\_\_\_  
Principal

\_\_\_\_\_  
Surety

\_\_\_\_\_  
Attest

\_\_\_\_\_  
Attest

\_\_\_\_\_

\_\_\_\_\_

STATE OF ILLINOIS                    )  
  ) S.S.  
COUNTY OF CHAMPAIGN            )

I, the undersigned Notary Public in and for the County and State aforesaid, do hereby certify that \_\_\_\_\_ personally known to me to be the \_\_\_\_\_ and personally known to me to be the person(s) whose name(s) is subscribed to the foregoing instrument as \_\_\_\_\_ appeared before me this day in person and severally acknowledged that \_\_\_\_\_ signed the said instrument as Principal, as \_\_\_\_\_ free and voluntary act.

GIVEN under my hand and official seal this \_\_\_\_\_ day of \_\_\_\_\_, \_\_\_\_\_.

\_\_\_\_\_

DRAINAGE CERTIFICATE- AS PER PUBLIC ACT 81-7831  
CHAPTER 109 - SECTION 2 - PARAGRAPHS 1 AND 2 -  
ILLINOIS REVISED STATUTES

- I. To the best of my knowledge and belief the drainage of surface waters will not be changed by the construction of \_\_\_\_\_  
Subdivision or any part thereof.

DATED this \_\_\_\_\_ day of \_\_\_\_\_, \_\_\_\_\_

\_\_\_\_\_  
Engineer's Name and Registration No.

\_\_\_\_\_  
Owner's Name or Attorney

- II. To the best of my knowledge and belief reasonable provisions have been made for the collection and diversion of surface waters into public areas, or drains which the subdivider has the right to use, and that such surface waters will be planned for in accordance with generally accepted engineering practices so as to reduce the likelihood of damage to the adjoining property because of the construction of \_\_\_\_\_  
\_\_\_\_\_ Subdivision.

DATED this \_\_\_\_\_ day of \_\_\_\_\_, \_\_\_\_\_

\_\_\_\_\_  
Engineer's Name and Registration No.

\_\_\_\_\_  
Owner's Name or Attorney

CERTIFICATE OF OWNER

The undersigned, being the Owner or Owners of the following described real estate situated in the Village of Philo, Champaign County, Illinois, to-wit: states that, the same was caused to be surveyed and platted by a Registered Illinois Land Surveyor, and the undersigned do hereby adopt, ratify and confirm prepared by said surveyor and named and Addition to the Village of Philo, Illinois, and the undersigned do hereby dedicate the tract marked "Streets", and that part set aside as Easements to the Village of Philo, Illinois, for public use, and the undersigned does dedicate for public use all of the utilities such as water mains, storm sewers and sanitary sewers to the Village of Philo, Illinois, and the public, for public use forever. Each of said lots in said Addition which there appears a broken line designated as "Public Utility Easement" is subject to a permanent easement five, often or proper feet in width as shown thereon for the installation and maintenance of gas, telephone and power lines, water and sewers, and any other utilities which may be needed for the benefit of any or all of the lots in said Addition.

There are also indicated and shown on said plat certain lines identified as "Building Setback Lines" and no buildings shall be erected on any of said lots in violation of any of said building setback lines, which are uniformly \_\_\_\_\_ feet from the front, \_\_\_\_\_ feet from the sides, and \_\_\_\_\_ feet from the rear, as the case may be, of said lots. For the purposes of this covenant, eaves, steps and open porches shall not be considered as a part of a building provided, however, that this shall not be construed to permit any portion of a building on a lot to encroach upon another lot or easement. (Other provisions optional).



STATE OF ILLINOIS            )  
  ) S.S.  
COUNTY OF CHAMPAIGN    )

COUNTY CLERK'S CERTIFICATE

I, the undersigned, County Clerk in and for the County of Champaign and State of Illinois, do hereby certify that I find no delinquent general taxes, unpaid current general taxes, delinquent special assessments or unpaid current special assessments against the following described tract of land, as appears from the records in my office to-wit:

Given under my hand and seal this \_\_\_\_\_ day of \_\_\_\_\_, \_\_\_\_\_

\_\_\_\_\_  
County Clerk of Champaign County

STATE OF ILLINOIS            )  
  )  
COUNTY OF CHAMPAIGN    ) S.S.  
  )  
VILLAGE OF PHILO            )

VILLAGE TREASURER'S CERTIFICATE

The undersigned, Treasurer of the Village of Philo, Champaign County, Illinois, does hereby certify that he finds no delinquent or unpaid special assessments levied against the following described real estate to-wit:

Given under my hand and seal this \_\_\_\_\_ day of \_\_\_\_\_, \_\_\_\_\_

\_\_\_\_\_  
Treasurer, Village of Philo  
Champaign County, Illinois

RIGHT-OF-WAY (MINIMUM WIDTH)

COLLECTOR - 80'

MAJOR - 80'

MINOR - 60'

CUL-DE-SAC - 60'

SIDEWALK TO BE LOCATED IN 5 FOOT EASEMENT

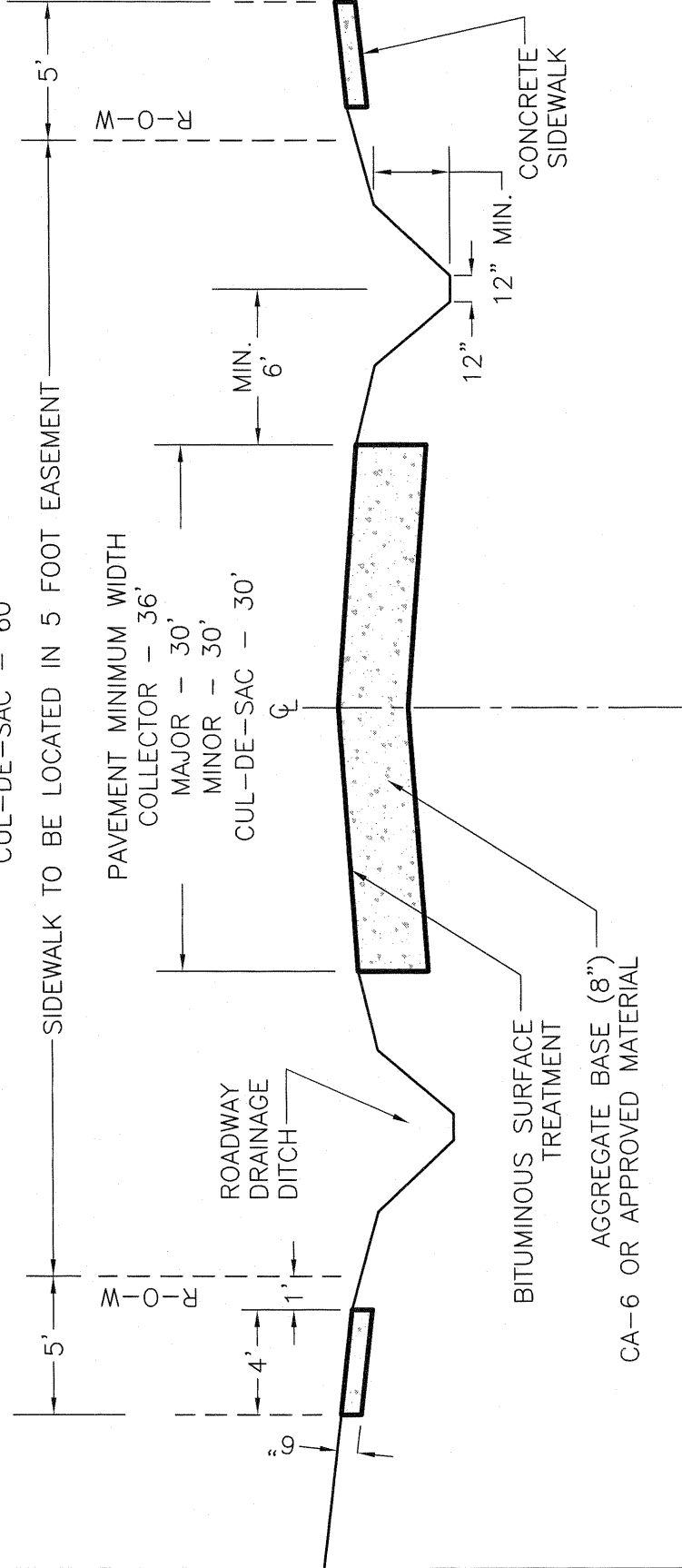

BITUMINOUS SURFACE TREATMENT

AGGREGATE BASE (8")  
CA-6 OR APPROVED MATERIAL

CONCRETE SIDEWALK

SURFACE TREATMENT SHALL CONSIST OF THE FOLLOWING:

- A. PRIME COAT, (0.3 G/SY)
- B. TWO SEPARATE APPLICATIONS OF A BITUMINOUS COVER COAT MATERIAL, AND COVER COAT AGGREGATE, CA-14 & CA-15, (0.40 G/SY, AND 35 POUNDS/SY,) PER APPLICATION.
- C. A BITUMINOUS SEAL COAT MATERIAL, AND SEAL COAT AGGREGATE, CA-15, (0.40 G/SY AND 35 POUNDS/SY)

**TYPICAL STREET CROSS SECTION  
RESIDENTIAL ZONING ONLY**

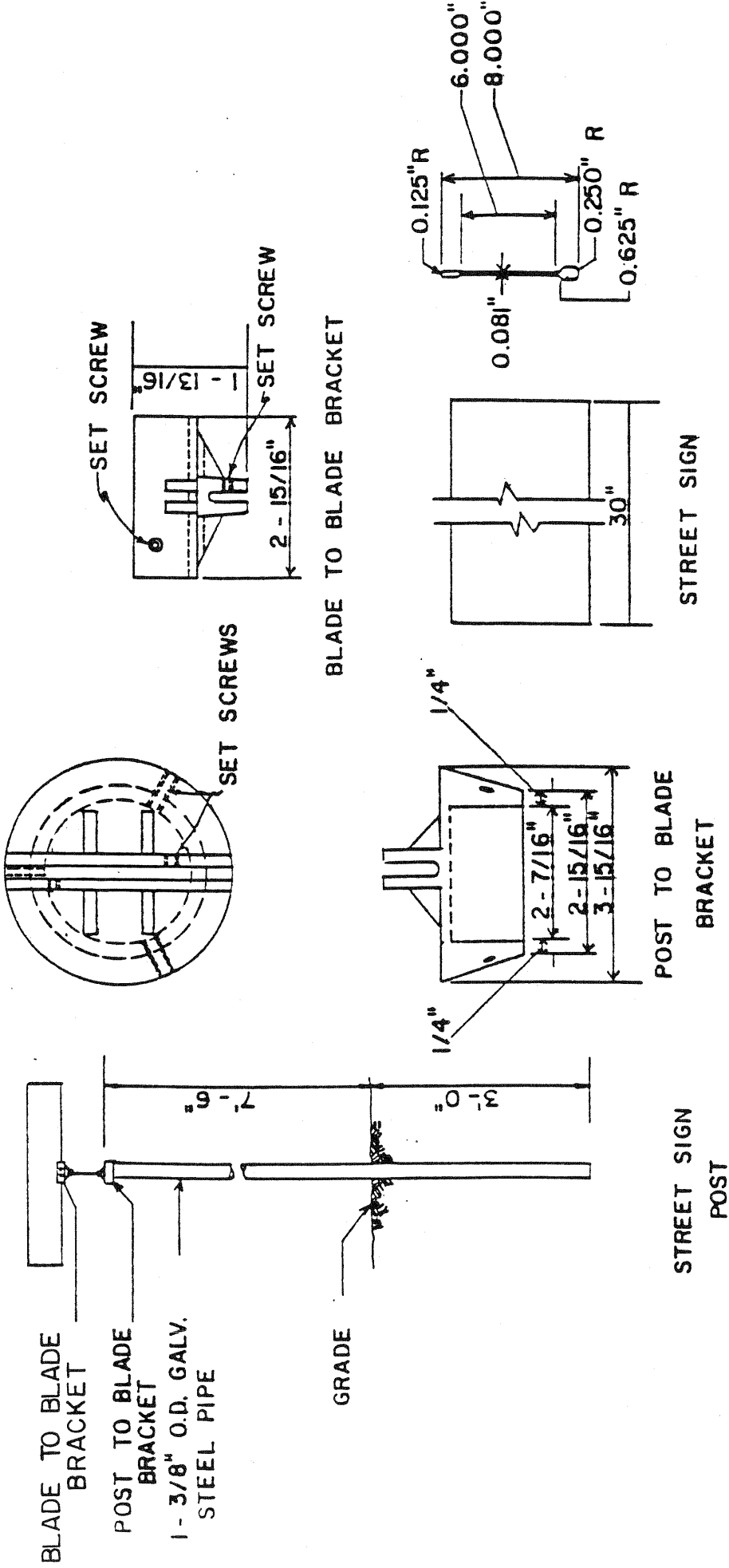

STREET SIGN - DETAIL

NOTE: STREET NAME SIGNS, PLAIN. PLATES ARE 18 GAUGE ZINC-COATED, BONDERIZED STEEL 6" HIGH BY 18" TO 32" LONG WITH 4" LETTERS. THREE COATS OF BAKED HIGH GLOSS ENAMEL. EMBOSSING IS 1/10" DEEP WITH WIDE ANGLE VISIBILITY. BRACKETS FOR STREET SIGNS ARE ZINC-COATED, BONDERIZED STEEL WITH CADMIUM PLATED BOLTS AND NUTS. STEEL PARTS ARE RUST PROOFED AND FINISHED WITH ENAMEL.

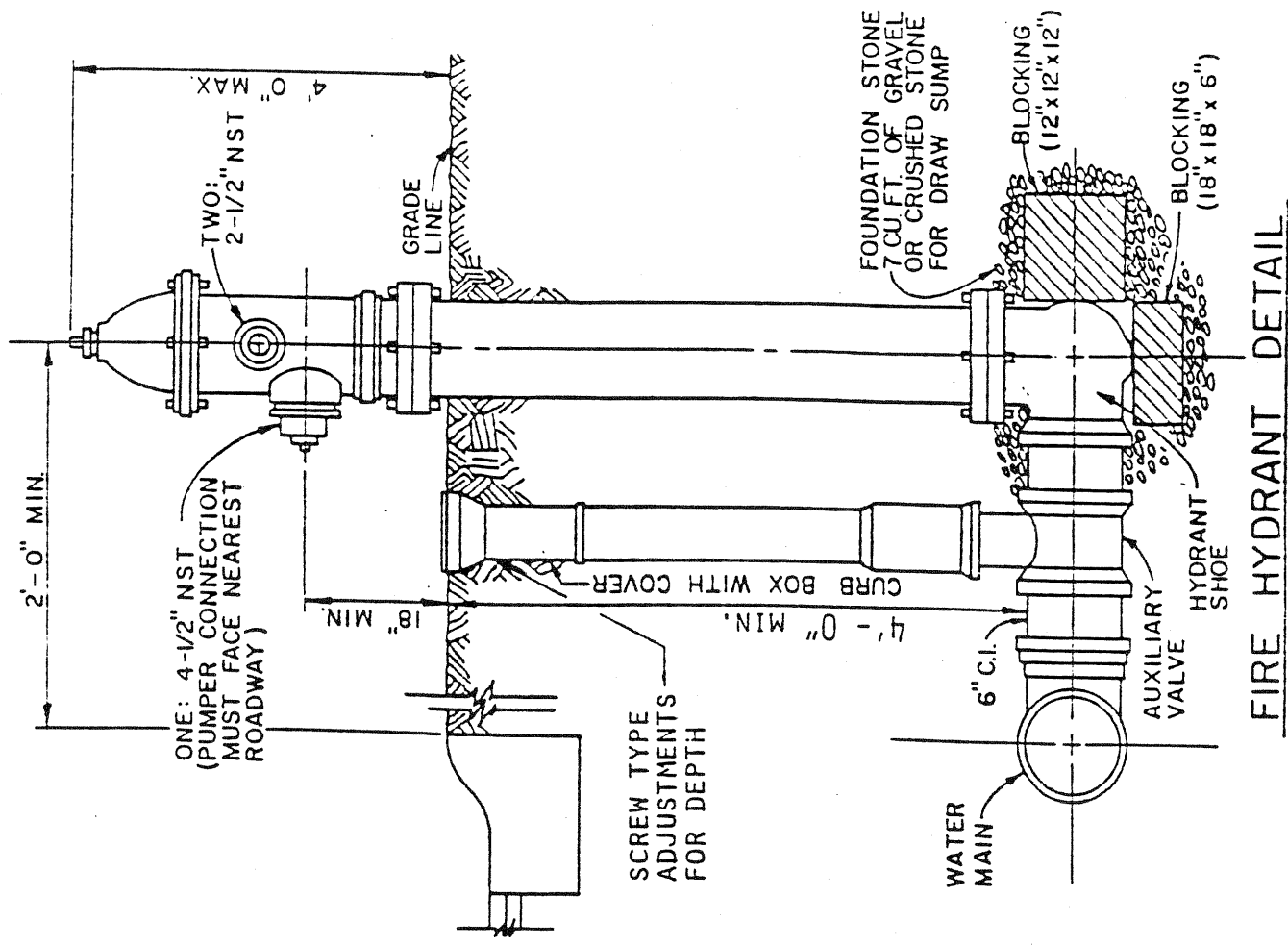

FIRE HYDRANT DETAIL

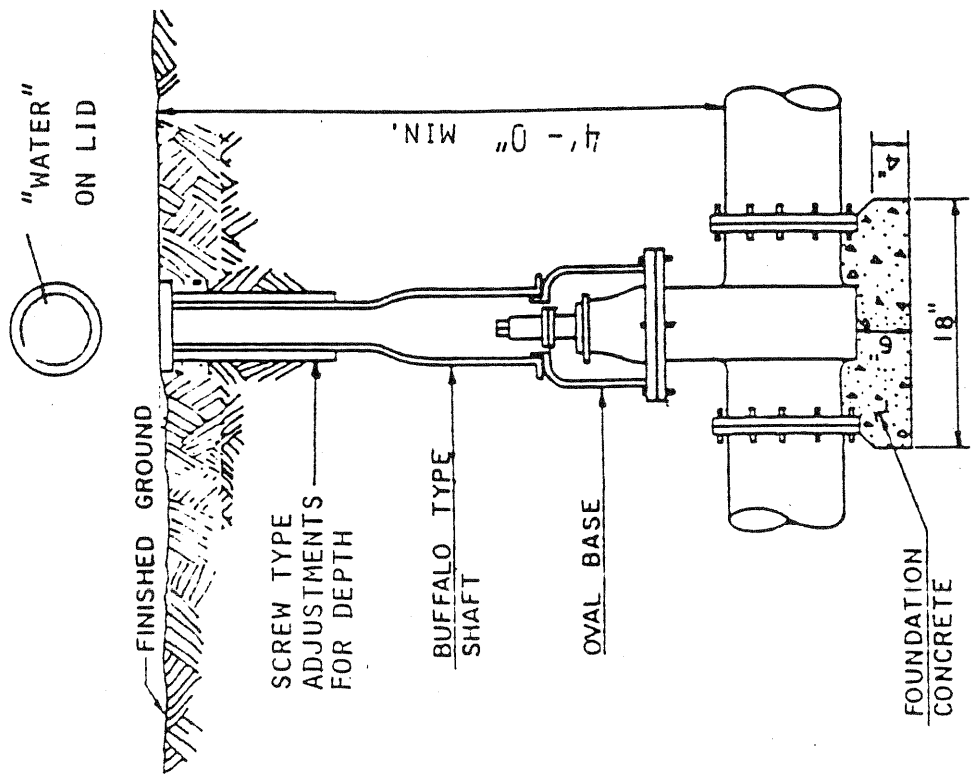

VALVE BOX DETAIL  
FOR  
WATER

BICYCLE PROOF LID

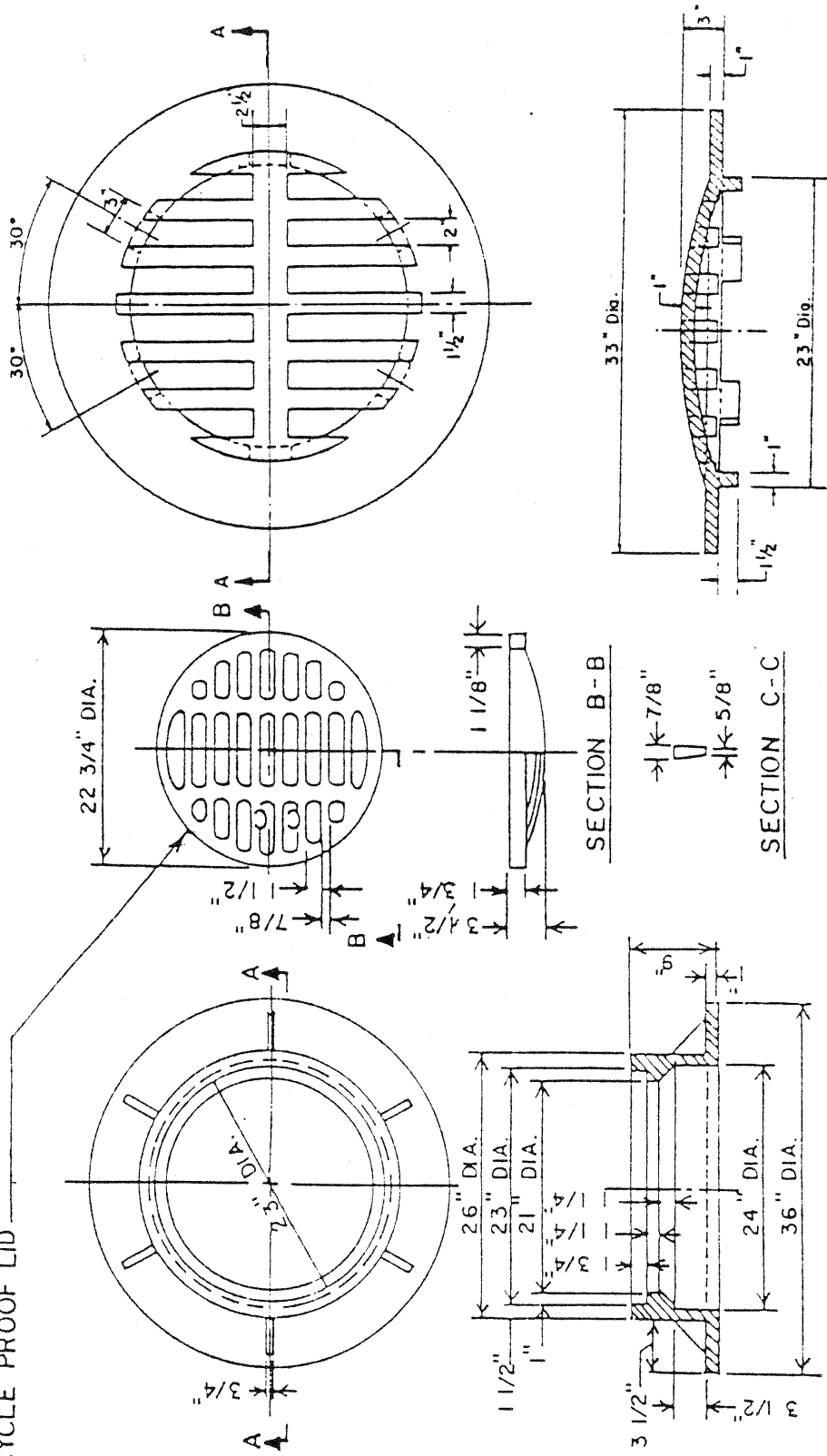

SECTION A-A

NEENAH R-1015 OR APPROVED EQUAL  
FRAME  
WT. 390 LBS.

SECTION B-B

STORM SEWERS  
OPEN LID  
WT. 116 LBS.

SECTION A-A

CAST GRATE  
WT. 200 LBS.

MANHOLE FRAME AND LID

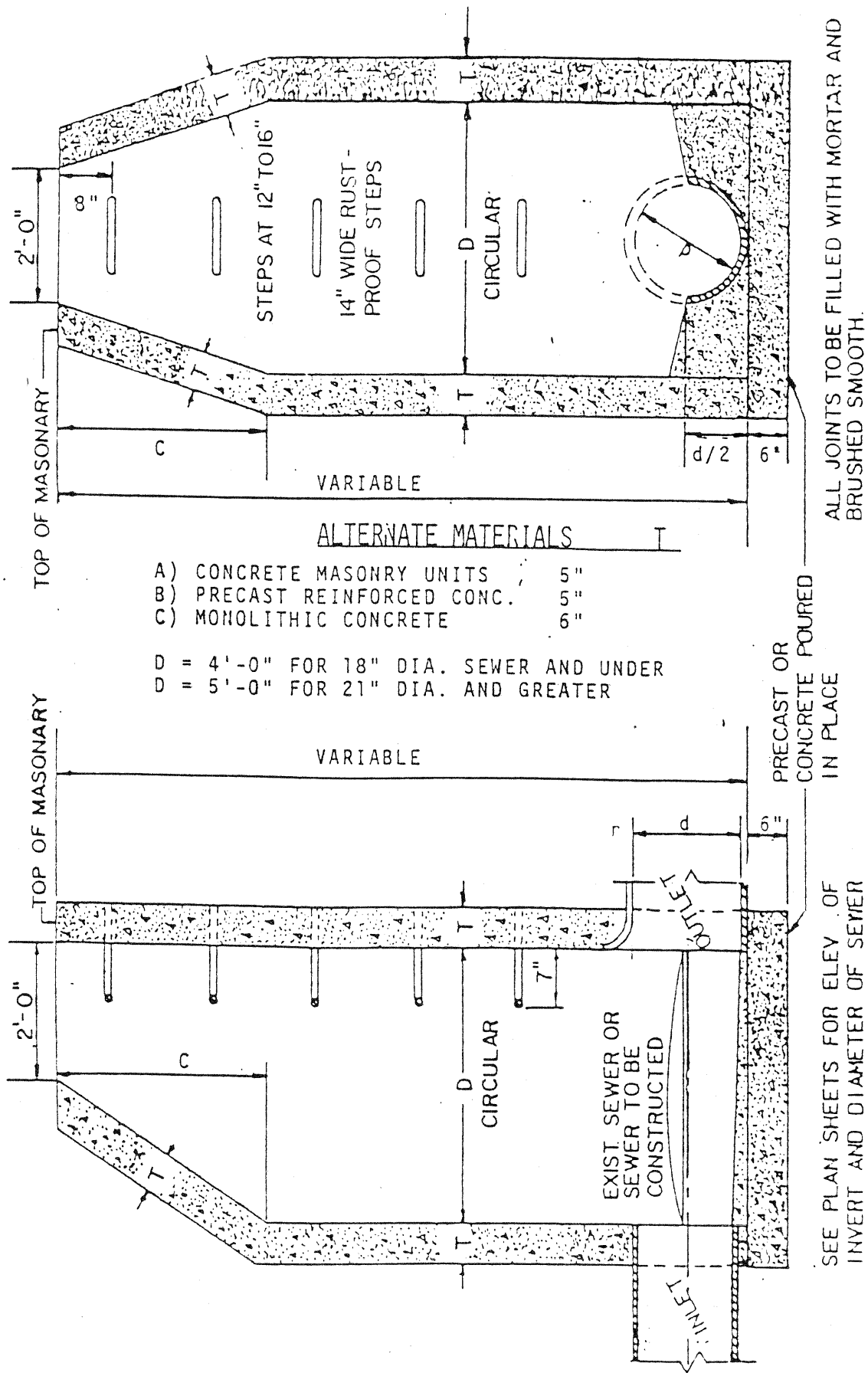

STORM SEWER MANHOLE DETAIL

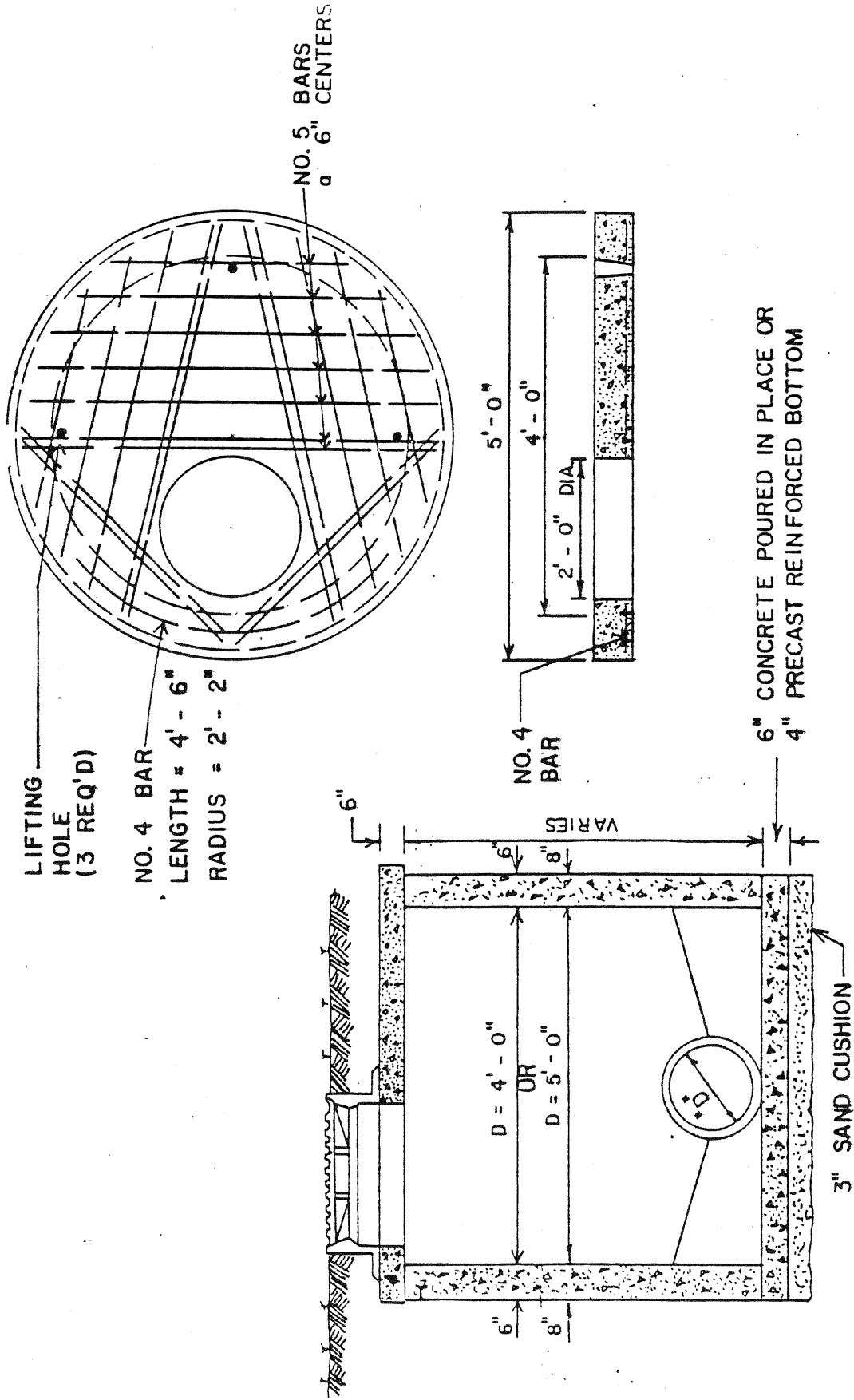

SHALLOW MANHOLE DETAIL

THIS APPLIES TO MANHOLE IN WHICH THE DIFFERENCE BETWEEN THE INVERT ELEVATION AND FINISH GRADE IS LESS THAN FOUR FEET



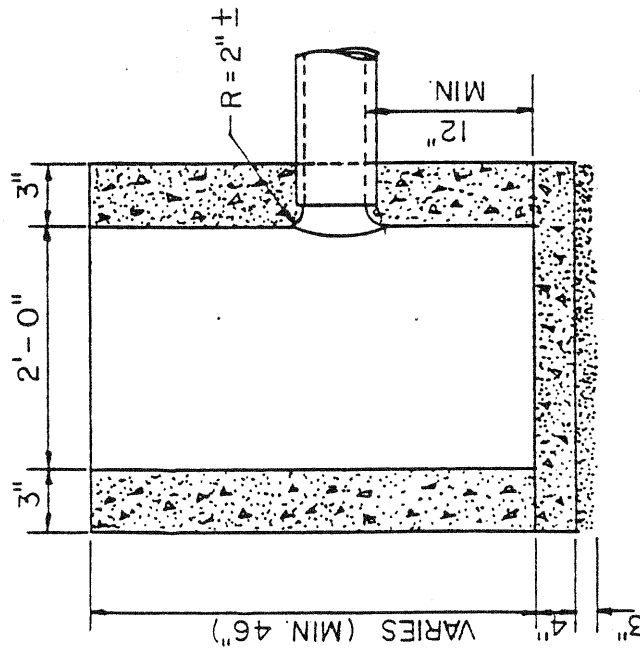

NOTE : ALL JOINTS TO BE FILLED WITH MORTAR AND BRUSHED SMOOTH.

CATCH BASIN